

# Nikon

## NIKKOR PC NIKKOR 19mm f/4E ED

En User's Manual

Printed in Japan  
SB6E01(11)  
7MA03311-01

NIKON CORPORATION

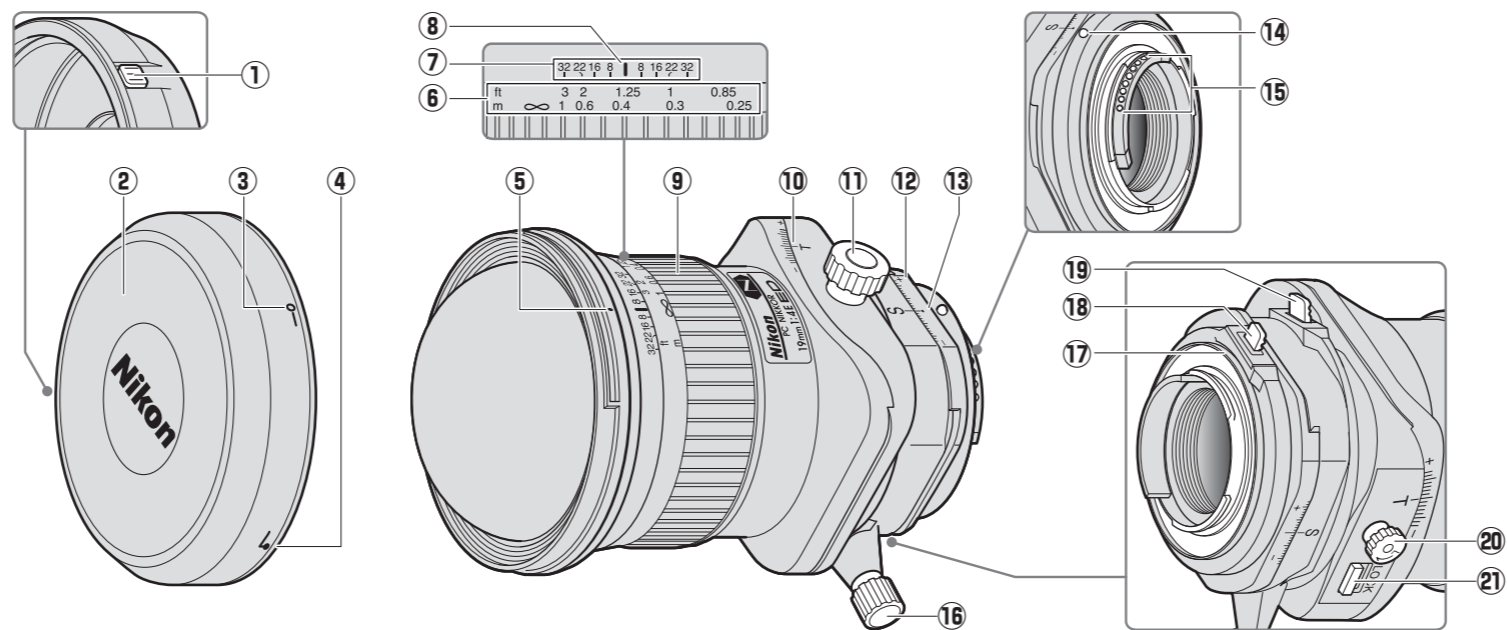

### Parts of the Lens

- 1 Lens cap lock release
- 2 Lens cap
- 3 Lens cap lock mark
- 4 Lens cap alignment mark
- 5 Lens cap mounting mark
- 6 Focus distance indicator
- 7 Depth-of-field indicator
- 8 Focus distance mark
- 9 Focus ring
- 10 Tilt scale
- 11 Tilt knob
- 12 Shift scale
- 13 Revolving index
- 14 Lens mounting mark
- 15 CPU contacts
- 16 Shift knob
- 17 Rubber lens-mount gasket
- 18 Revolving lever
- 19 PC revolving lever
- 20 Tilt lock knob
- 21 Tilt lock switch

Before using this product, please carefully read both these instructions and the camera manual.

**Note:** This lens does not support D2- or D1-series, D200, D100, D90, D80, D70-series, D60, D50, D40-series, or D3000 digital SLR cameras or film SLR cameras.

This is a manual focus lens; autofocus is not supported. Manual focus is available regardless of the focus mode selected with the camera.

### About This Lens

This lens features shift and tilt mechanisms that can be used to control perspective. The optical axis of the lens can be shifted to reduce the effects of perspective when photographing subjects at an angle or tilted to bring both foreground and background into focus without stopping down aperture.

#### Shift

"Shift" shifts the optical axis of the lens away from the center of the frame, allowing photos to be framed anywhere in the image circle. It can be used to reduce the effects of perspective when photographing buildings from low angles or to change the composition without angling or moving the camera.

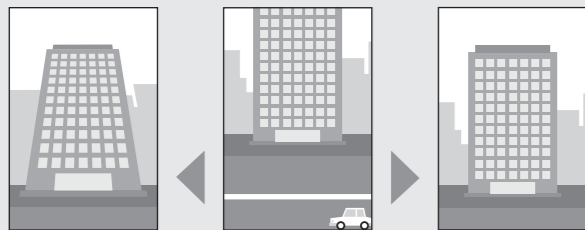

Camera angled up    Camera pointed straight ahead    Lens shifted with camera still pointed straight ahead

#### Tilt

The optical axis of the lens is normally perpendicular to the focal plane. "Tilt" deliberately angles the optical axis so that objects at different distances from the camera can be kept in focus without stopping down aperture, reducing depth of field and ensuring that the background remains blurred.

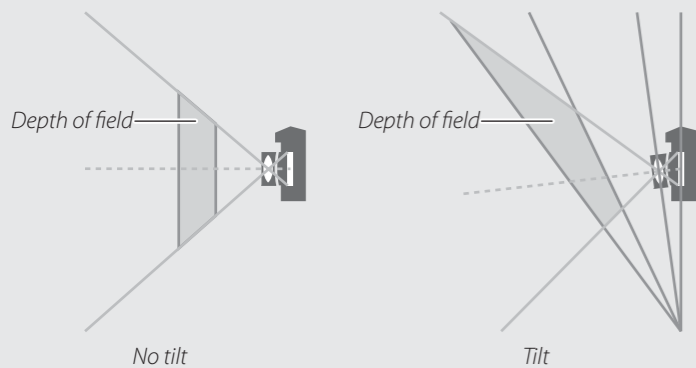

**Note:** Images are for illustrative purposes only.

### For Your Safety

To prevent damage to property or injury to yourself or to others, read "For Your Safety" in its entirety before using this product.

Keep these safety instructions where all those who use this product will read them.

**WARNING:** Failure to observe the precautions marked with this icon could result in death or severe injury.

**CAUTION:** Failure to observe the precautions marked with this icon could result in injury or property damage.

#### WARNING

**Do not disassemble or modify this product.**  
**Do not touch internal parts that become exposed as the result of a fall or other accident.**  
Failure to observe these precautions could result in electric shock or other injury.

**Should you notice any abnormalities such as the product producing smoke, heat, or unusual odors, immediately disconnect the camera power source.**  
Continued operation could result in fire, burns or other injury.

**Keep dry.**  
**Do not handle with wet hands.**  
Failure to observe these precautions could result in fire or electric shock.

**Do not use this product in the presence of flammable dust or gas such as propane, gasoline or aerosols.**  
Failure to observe this precaution could result in explosion or fire.

**Do not directly view the sun or other bright light source through the lens or camera.**  
Failure to observe this precaution could result in visual impairment.

**Keep this product out of reach of children.**  
Failure to observe this precaution could result in injury or product malfunction. In addition, note that small parts constitute a choking hazard. Should a child swallow any part of this product, seek immediate medical attention.

**Do not handle with bare hands in locations exposed to extremely high or low temperatures.**  
Failure to observe this precaution could result in burns or frostbite.

#### CAUTION

**Do not leave the lens pointed at the sun or other strong light sources.**  
Light focused by the lens is a source of fire and damage to the product's internal parts.

**Do not leave the product where it will be exposed to extremely high temperatures, for an extended period such as in an enclosed automobile or in direct sunlight.**  
Failure to observe this precaution could result in fire or product malfunction.

### Notice for Customers in Canada

CAN ICES-3 B / NMB-3 B

### Attaching and Removing the Lens Cap

#### Attaching the Cap

Align the lens cap mounting mark (●) with the lens cap alignment mark (◀, ①) and then rotate the cap (②) until it clicks into place (③).

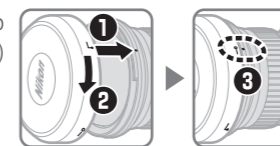

#### Removing the Cap

Keeping the lens cap lock release pressed (①), rotate (②) and remove (③) the lens cap.

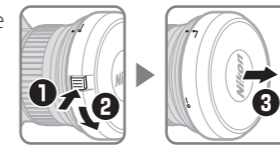

The front element of the lens projects past the lens body. Keep the cap attached to protect the lens when it is not in use.



### Attaching and Removing the Lens

You could pinch your fingers if you attach the lens with it shifted, tilted, or rotated. Before attaching the lens, rotate the shift and tilt knobs to center the scales and then slide the tilt lock switch to the LOCK position.

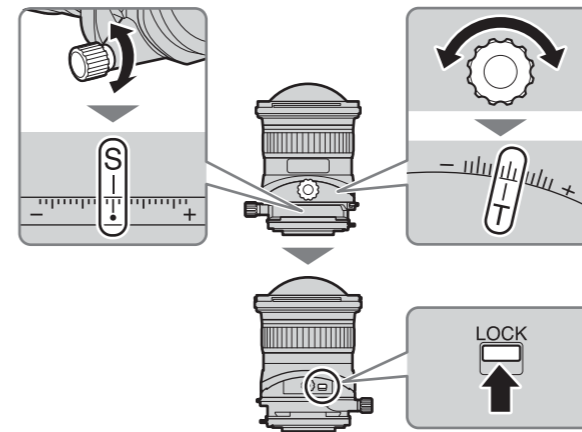

#### Attaching the Lens

Be careful not to pinch your fingers when attaching the lens.

- 1 Turn the camera off and remove the camera body cap.
- 2 Remove the rear lens cap.
- 3 Keeping the lens mounting mark aligned with the mounting mark on the camera body, position the lens in the camera's bayonet mount and then rotate the lens counterclockwise until it clicks into place with the lens mounting mark at the top.

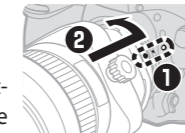

## Using the Lens

The lens can be shifted vertically or horizontally, tilted, rotated, or rotated to change the tilt and shift direction (perspective control rotation, or "PC rotation" for short).

With cameras other than the D5, D4 series, D3 series, D810 series, and D500, some combinations of shift and rotation may not be available due to the lens contacting the camera body.

### Rotating the Lens

*Be careful not to pinch your fingers when rotating the lens.*

The lens can be rotated up to 90° in either direction, with stops at 30° and 60°. Press the revolving lever in toward the camera and rotate the square base, lifting your finger from the revolving lever immediately after beginning the turn to prevent injury due to contact with the edges of the lens.

Before rotating the lens, center the shift and tilt scales and slide the tilt lock switch to the **LOCK** position.

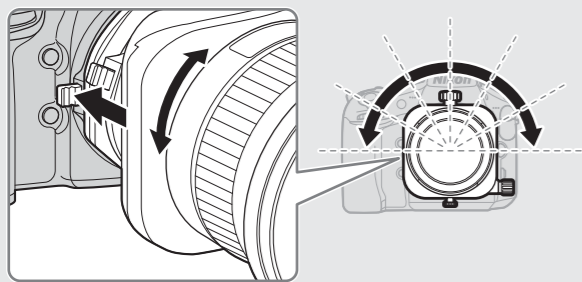

### Shift

*Observe caution when handling the edges of the lens. Contact with sharp edges could result in injury.*

Rotate the shift knob to shift the lens horizontally or vertically.

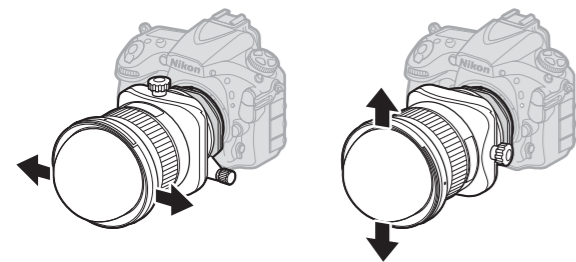
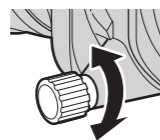

### Tilt

*Observe caution when handling the edges of the lens. Contact with sharp edges could result in injury.*

To unlatch the tilt knob, slide the lock switch from the **LOCK** position and rotate the lock knob in the direction opposite to that shown by the arrow. You can then tilt the lens horizontally or vertically by rotating the tilt knob. Once the lens is at the desired angle, rotate the tilt lock knob to lock it in place.

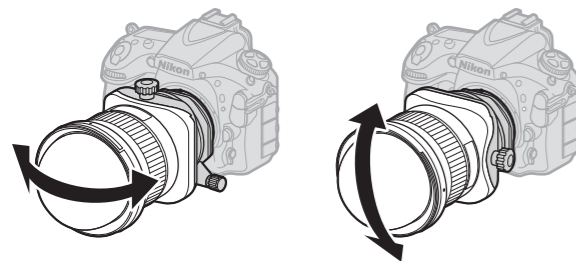
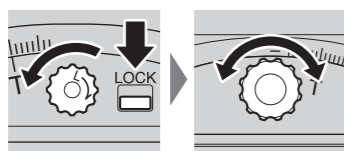

### The Tilt Lock Switch

The tilt lock switch locks the lens at zero tilt. Rotate the tilt knob to center the tilt scale and slide the switch to the **LOCK** position.



### Rotating Tilt Relative to Shift (PC Rotation)

*Be careful not to pinch your fingers when rotating the lens.*

The tilt mechanism can be rotated up to 90° as shown to make tilt parallel or perpendicular to shift. Press the PC revolving lever in toward the camera and rotate the square base, lifting your finger from the lever after beginning the turn. The tilt mechanism can be rotated to any position, with a stop at 45°.

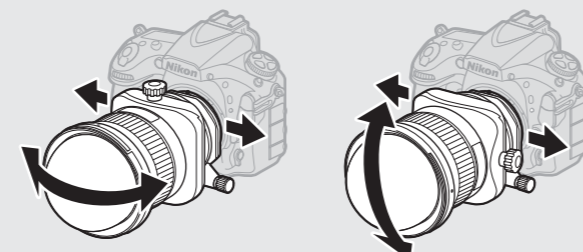
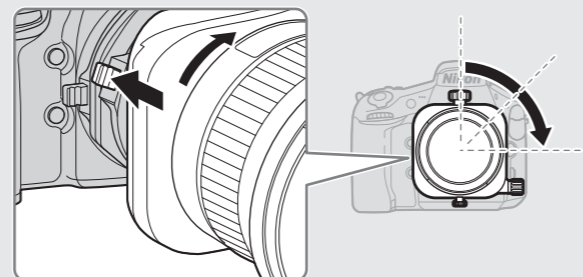

### Tilt and Shift Controls

Do not use excessive force when handling the knobs and tilt lock knob and be sure to release the tilt lock switch and tilt lock knob before using the tilt knob.

Shadows and uneven colors may appear in photographs taken with shift or tilt. Vignette control may not produce the desired results, while using the electronic front-curtain shutter may result in photos marred by fog or lines; before shooting, disable vignette control and, if necessary, the electronic shutter. The built-in flash can not be used.

### Lens Care

- The lens returns to maximum aperture when removed from the camera. Replace the lens caps to protect the interior of the lens.
- Do not pick up or carry the lens by the lens caps.
- The many moving parts of the lens are vulnerable to dust and moisture. Be sure the lens is not tilted or shifted when it is not in use.
- Keep the CPU contacts clean.
- Should the rubber lens-mount gasket be damaged, cease use immediately and take the lens to a Nikon-authorized service center for repair.
- Removing dust is normally sufficient to clean the glass surfaces of the lens.
- The fluorine-coated front element can be cleaned simply by wiping it with a dry cloth. Fingerprints and other stains can be removed using a soft, clean cotton cloth or lens cleaning tissue; clean from the center outwards using a circular motion, taking care not to leave smears or touch the glass surface with your fingers. To remove stubborn stains, wipe gently using a soft cloth dampened with a small amount of distilled water, ethanol, or lens cleaner. Drop-shaped stains on the water- and oil-repellent fluorine-coated element can be removed with a dry cloth.
- To remove smudges and fingerprints from the rear lens element (the element at the mount end of the lens), apply a small amount of ethanol or lens cleaner to a soft, clean cotton cloth or lens-cleaning tissue and clean from the center outwards using a circular motion, taking care not to leave smears or touch the glass with your fingers.
- Never use organic solvents such as paint thinner or benzene to clean the lens.
- Attach the front and rear caps before placing the lens in its lens case.
- If the lens will not be used for an extended period, store it in a cool, dry location to prevent mold and rust. Do not store in direct sunlight or with naphtha or camphor moth balls.
- Keep the lens dry. Rusting of the internal mechanism can cause irreparable damage.
- Leaving the lens in extremely hot locations could damage or warp parts made from reinforced plastic.

- With its wide field of view and projecting front element, the lens is vulnerable to stray light that can cause flares or ghosting. We recommend using a shade or the like to shut out unwanted light.

- Rapid changes in temperature may cause damaging condensation inside and outside the lens. Before taking the lens from a warm to a cold environment or vice versa, place it in its case or a plastic bag to slow the change in temperature.

### Supplied Accessories

- Slip-on front lens cap
- LF-4 Rear Lens Cap
- CL-1120 Lens Case

### Specifications

Type	Type E PC lens with built-in CPU and F mount
Focal length	19 mm
Maximum aperture	f/4
Lens construction	17 elements in 13 groups (including 3 ED elements, 2 aspherical elements, and elements with Nano-Crystal or fluorine coatings)
Angle of view	<ul style="list-style-type: none"> <li>Nikon FX-format D-SLR cameras: 97°</li> <li>Nikon DX-format D-SLR cameras: 73°</li> </ul>
Focusing	Manual focus only
Focus distance indicator	0.25 m – ∞
Minimum focus distance	0.25 m (0.9 ft) from focal plane
Diaphragm blades	9 (rounded diaphragm opening)
Diaphragm	Automatic electronic aperture control
Aperture range	f/4 – 32
Perspective control	Horizontal and vertical shift and tilt <ul style="list-style-type: none"> <li>Shift: ±12 mm</li> <li>Tilt: ±7.5°</li> </ul>
Rotation	Rotates 90° left and right with stops every 30°; tilt mechanism rotates 90° left with a stop at 45°.
Dimensions	Approx. 89 mm maximum diameter × 124 mm (distance from camera lens mount flange)
Weight	Approx. 885 g (1 lb 15.3 oz)

*Nikon reserves the right to change the appearance, specifications, and performance of this product at any time and without prior notice.*



*Photo taken with no shift or tilt*



*Photo taken with the lens shifted, then rotated using PC rotation and tilted*