

**Nikon**

# NIKKOR

## NIKKOR Z 70-200mm f/2.8 VR S II

### Reference Guide

- Read this document thoroughly before using the product.
- To ensure proper use of the product, be sure to read “For Your Safety” (page 5).
- After reading this document, keep it readily accessible for future reference.

**NIKON CORPORATION**

© 2026 Nikon Corporation



SB5L01(11)  
7MM06811-01

En

# Table of Contents

<b>Introduction</b> .....	<b>4</b>
Before You Begin .....	4
For Your Safety .....	5
<b>Using the Lens</b> .....	<b>8</b>
Parts of the Lens: Names and Functions .....	8
Attaching and Removing the Tripod Collar Ring and Protective Cover .....	21
Attachment and Removal .....	28
Using the Lens Hood .....	33
Using the Tripod Collar Ring .....	37
Vibration Reduction (VR) .....	40
Note on Zooming with the Zoom Ring .....	41
Precautions for Use .....	42
Lens Maintenance .....	43
<b>Technical Notes</b> .....	<b>44</b>
Cameras with AF-Assist Illuminators .....	44
Using the Lens on Cameras with a Built-in Flash .....	45
Accessories .....	46
Specifications .....	48

Notices..... 50

# Introduction

## Before You Begin

Before using this product, please read these instructions carefully. You will also need to consult the documentation provided with the camera.

- This lens is intended exclusively for use with mirrorless cameras featuring a Nikon Z mount.
- Update the camera firmware to the latest version. With earlier versions, the camera may fail to detect the lens correctly and some features may not be available. The latest version of the camera firmware can be downloaded from the Nikon Download Center at the URL below.

<https://downloadcenter.nikonimglib.com/>

No reproduction in any form of this document, in whole or in part (except for brief quotation in critical articles or reviews), may be made without written authorization from NIKON CORPORATION.

# For Your Safety

To prevent damage to property or injury to yourself or to others, read "For Your Safety" in its entirety before using this product.

After reading these safety instructions, keep them readily accessible for future reference.



**WARNING:** Failure to observe the precautions marked with this icon could result in death or severe injury.



**CAUTION:** Failure to observe the precautions marked with this icon could result in injury or property damage.



## WARNING

**Do not disassemble or modify this product. Do not touch internal parts that become exposed as the result of a fall or other accident.**

Failure to observe these precautions could result in electric shock or other injury.

**Should you notice any abnormalities such as the product producing smoke, heat, or unusual odors, immediately disconnect the camera power source.**

Continued operation could result in fire, burns or other injury.

**Keep dry. Do not handle with wet hands.**

Failure to observe these precautions could result in fire or electric shock.

**Do not use this product in the presence of flammable dust or gas such as propane, gasoline or aerosols.**

Failure to observe this precaution could result in explosion or fire.



## WARNING

**Do not directly view the sun or other bright light source through the lens.**

Failure to observe this precaution could result in visual impairment.

**Keep this product out of reach of children.**

Failure to observe this precaution could result in injury or product malfunction.

In addition, note that small parts constitute a choking hazard. Should a child swallow any part of this product, seek immediate medical attention.

**Do not entangle, wrap or twist the straps around your neck.**

Failure to observe this precaution could result in accidents.

**Do not handle with bare hands in locations exposed to extremely high or low temperatures.**

Failure to observe this precaution could result in burns or frostbite.



## CAUTION

**Do not leave the lens pointed at the sun or other strong light sources.**

Light focused by the lens could cause fire or damage to product's internal parts. When shooting backlit subjects, keep the sun well out of the frame. Sunlight focused into the camera when the sun is close to the frame could cause fire.

**Do not leave the product where it will be exposed to extremely high temperatures for an extended period, such as in an enclosed automobile or in direct sunlight.**

Failure to observe this precaution could result in fire or product malfunction.

**Do not transport cameras or lenses with tripods or similar accessories attached.**

Failure to observe this precaution could result in injury or product malfunction.

**Keep the product at least 5 cm (2.0 in.) from pacemakers and other medical devices.**

Medical devices in close proximity could be affected by the magnet or magnets in the product.

# Using the Lens

## Parts of the Lens: Names and Functions

The parts of the lens are listed below.

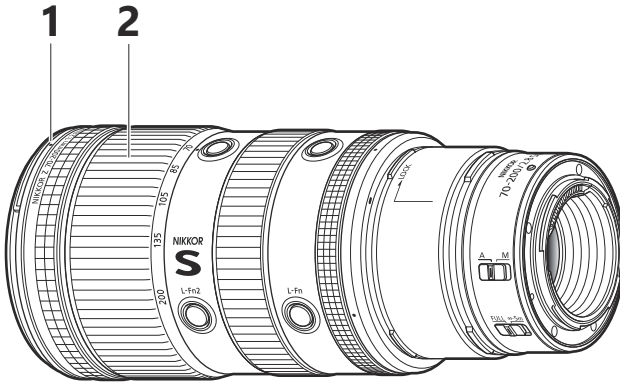

### 1 Lens hood mounting mark

Use when attaching the lens hood.

 ["Using the Lens Hood" \(p.33\)](#)

### 2 Zoom ring

Rotate the ring to zoom in or out.

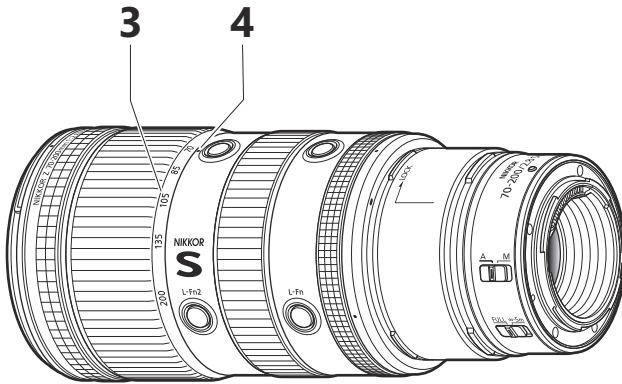

### 3 Focal length scale

Determine the approximate focal length when zooming the lens in or out.

### 4 Focal length mark

Determine the approximate focal length when zooming the lens in or out.

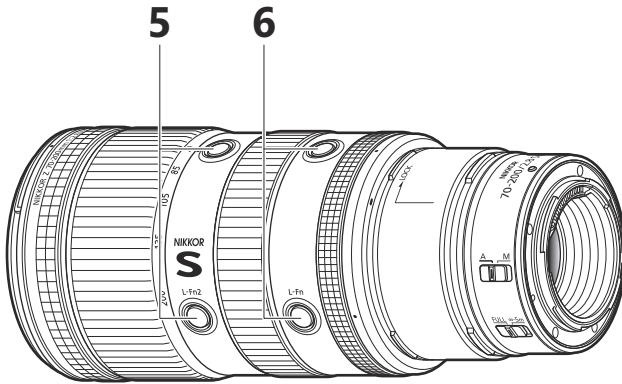

## 5 L-Fn2 buttons

Press to perform a function assigned using the camera. For more information, see the description of [**Custom control assignment**], [**Custom controls**], or [**Custom controls (shooting)**] in the documentation provided with the camera. There are four buttons positioned around the lens at 90° intervals.

## 6 L-Fn buttons

Press to perform a function assigned using the camera. For more information, see the description of [**Custom control assignment**], [**Custom controls**], or [**Custom controls (shooting)**] in the documentation provided with the camera.

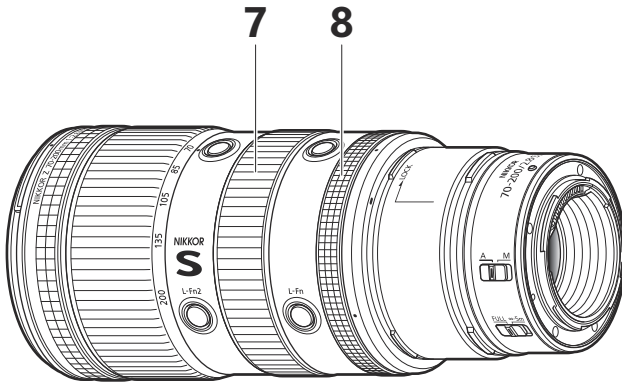

## 7 Focus ring

Use for manual focus.

- When focusing using autofocus, you can adjust focus manually by rotating the ring while the shutter-release button is pressed halfway.

### Focus

Due to the design of the focus system, shaking the lens while the camera is off may cause it to rattle; this does not indicate a malfunction.

## 8 Control ring

Rotate to adjust a setting such as **[Aperture]** or **[Exposure compensation]** assigned using the camera. For more information, see the description of **[Custom control assignment]**, **[Custom controls]**, or **[Custom controls (shooting)]** in the documentation provided with the camera.

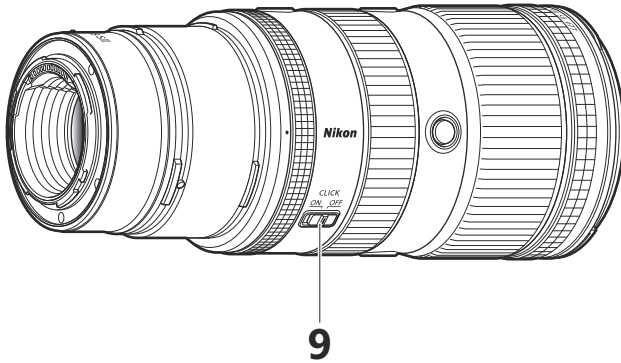

## 9 Control ring clicking switch

Toggle the tactile click on or off during control ring operations.

- **ON:** The control ring provides tactile clicks during rotation. Each click of rotation changes the value of the function assigned to the control ring by one step.\*
- **OFF:** The control ring rotates without clicking.

\* *This feature is not available with Z7, Z6, Z50, Z30, or Zfc cameras (as of September 2025). Keep the control ring clicking switch set to the OFF position.*

### Muting the Control Ring Click Sound During Recording

When the control ring clicking switch is set to ON, the clicking sound from the control ring's rotation will be audible in video footage. Change the setting of the control ring clicking switch to OFF to turn off the clicking sound.

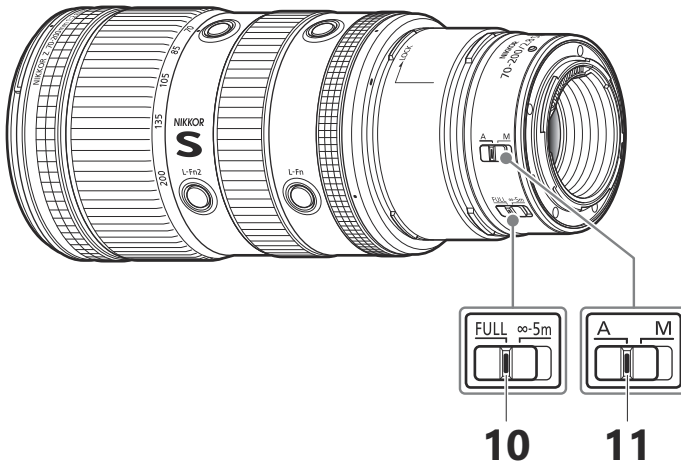

## 10 Focus limit switch

Choose the autofocus range.

- **FULL**: Choose to focus on subjects at any distance between the minimum focus distance and  $\infty$ .
- **$\infty$  – 5 m**: Focus is limited to distances of 5 m (16.41 ft) and more. Select this option for faster focusing if your subject will always be at a distance of at least 5 m (16.41 ft).

## 11 Focus-mode switch

Choose a focus mode.

- **A**: Autofocus
- **M**: Manual focus

Note that regardless of the setting chosen, focus must be adjusted manually when manual focus mode is selected using camera controls.

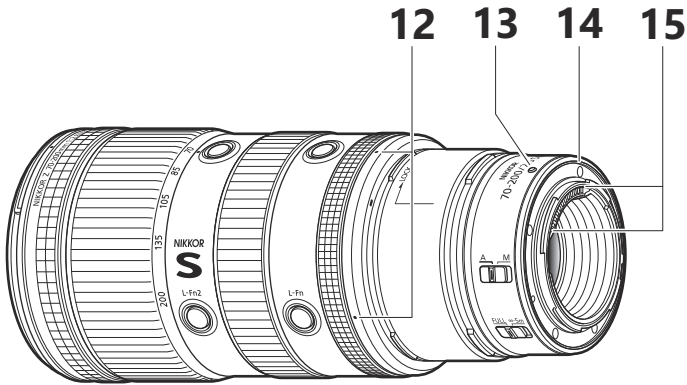

## 12 Lens rotation indices

Use when rotating the camera to shoot in landscape (“wide”) or portrait (“tall”) orientation. There are four indices positioned around the lens at 90° intervals.

 [“Using the Tripod Collar Ring” \(p.37\)](#)

## 13 Lens mounting mark

Use when mounting the lens on the camera.

 [“Attachment and Removal” \(p.28\)](#)

## 14 Rubber lens-mount gasket

Helps prevent the ingress of water droplets or dust along the surfaces where the lens and camera meet when the lens is mounted on the camera.\*

\* *There is no guarantee that the gasket is completely proof against the ingress of water droplets or dust in all circumstances.*

## 15 CPU contacts

Used to transfer data to and from the camera.

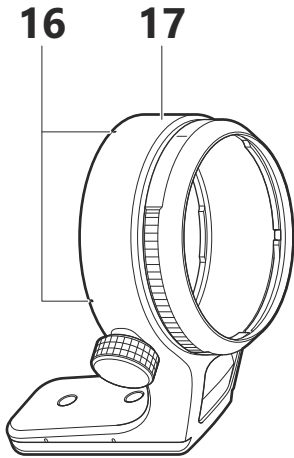

### **16 Tripod collar ring rotation indices**

Use when rotating the camera to shoot in landscape (“wide”) or portrait (“tall”) orientation. There are three indices positioned around the tripod collar ring at 90° intervals.

 [“Using the Tripod Collar Ring” \(p.37\)](#)

### **17 Tripod collar ring**

The camera can be rotated between “wide” and “tall” orientations when a tripod is attached to the tripod collar.

 [“Using the Tripod Collar Ring” \(p.37\)](#)

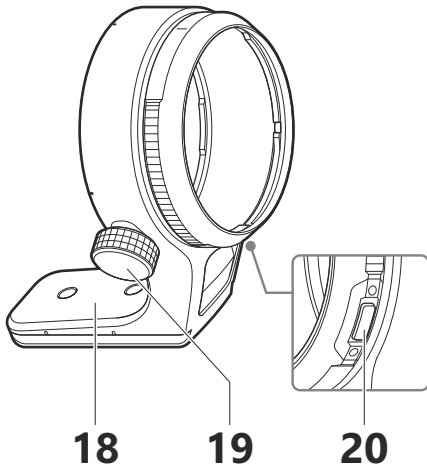

### **18 Tripod collar**

Attach a tripod.

 ["Attaching and Removing the Tripod Collar Ring and Protective Cover"](#)  
(p.21)

### **19 Tripod collar ring attachment screw**

Fix the tripod collar ring in place.

 ["Attaching and Removing the Tripod Collar Ring and Protective Cover"](#)  
(p.21)

### **20 Tripod collar ring release button**

Use when removing the tripod collar ring.

 ["Attaching and Removing the Tripod Collar Ring and Protective Cover"](#)  
(p.21)

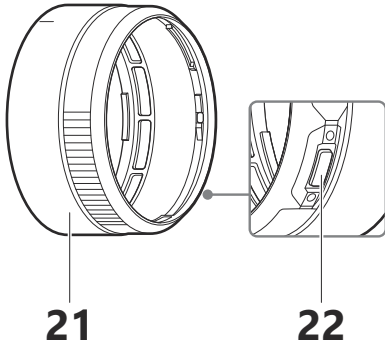

## 21 Protective cover

Protects the tripod collar ring mount on the lens. Use when the tripod collar ring is detached.

 ["Attaching and Removing the Tripod Collar Ring and Protective Cover"](#)  
(p.21)

## 22 Protective cover release button

Use when removing the protective cover.

 ["Attaching and Removing the Tripod Collar Ring and Protective Cover"](#)  
(p.21)

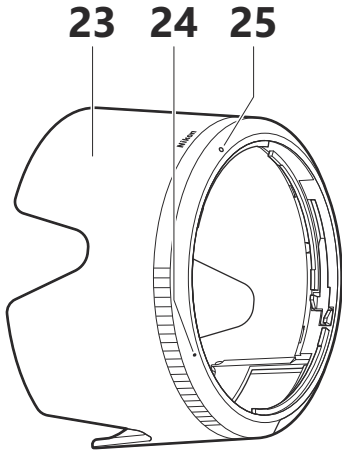

### **23 Lens hood**

Lens hoods reduce stray light that would otherwise cause flare or ghosting. They also serve to protect the lens.

📖 ["Using the Lens Hood" \(p.33\)](#)

### **24 Lens hood alignment mark**

Use when attaching the lens hood.

📖 ["Using the Lens Hood" \(p.33\)](#)

### **25 Lens hood lock mark**

Use when attaching the lens hood.

📖 ["Using the Lens Hood" \(p.33\)](#)

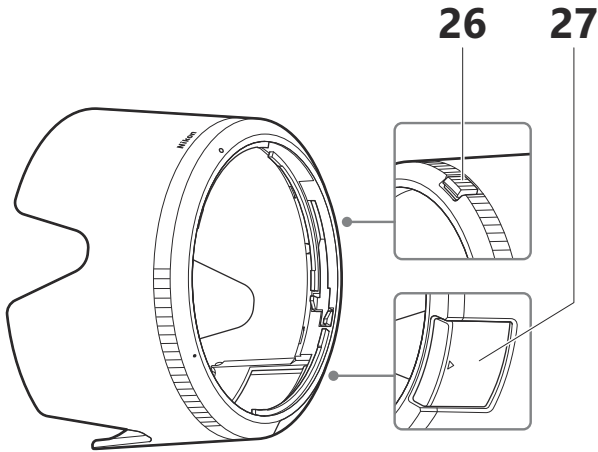

## **26 Lens hood lock release button**

Use when removing the lens hood.

📖 ["Using the Lens Hood" \(p.33\)](#)

## **27 Filter adjustment window**

Use when rotating a filter such as circular polarizing filters to adjust the effect without removing the lens hood.

📖 ["Using the Lens Hood" \(p.33\)](#)

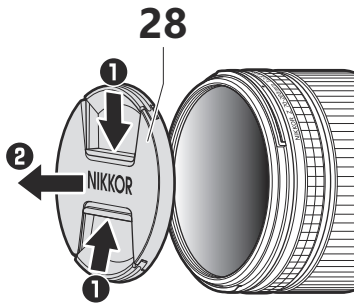

**28 Lens cap (front cap)**

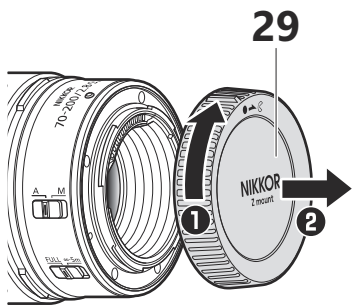

**29 Lens cap (rear cap)**

# Attaching and Removing the Tripod Collar Ring and Protective Cover

## ✓ The Tripod Collar Ring and Protective Cover

A removable tripod collar ring and protective cover are supplied with the lens. Ensure that either the tripod collar ring or protective cover is attached to protect the tripod collar ring mount on the lens.

## Tripod Collar Ring

### Attaching the Tripod Collar Ring

1. Confirm that the tripod collar ring attachment screw on the tripod collar ring is fully tightened.

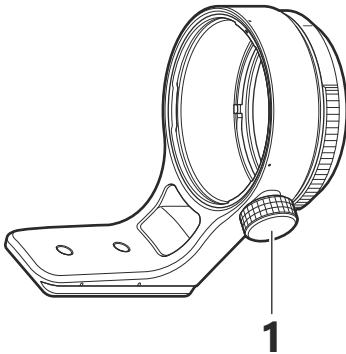

1 Tripod collar ring attachment screw

### **Aligning the Tripod Collar Ring Indices**

Align the tripod collar ring rotation index on top of the tripod collar ring with the index on the moving part of the tripod collar ring as described below:

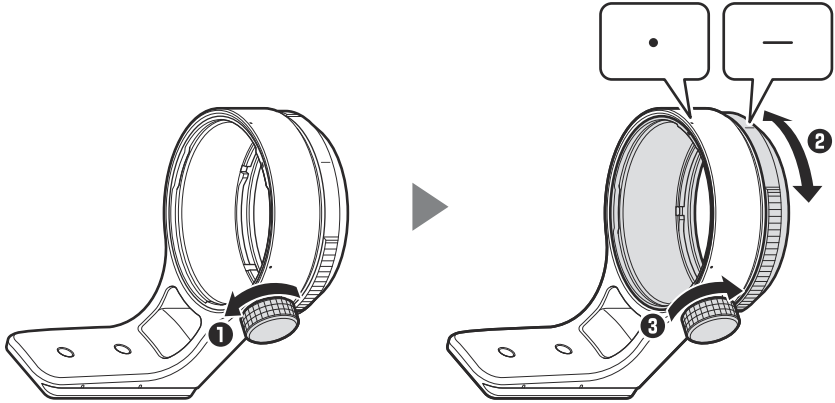

- Loosen the tripod collar ring attachment screw (1).
- Rotate the moving part of the tripod collar ring and align its index with the tripod collar ring rotation index (2).
- Fully tighten the tripod collar ring attachment screw (3).

## 2. Align the indices on the tripod collar ring and the lens as shown and attach the tripod collar ring to the lens.

- Loosen the tripod collar ring attachment screw if you have difficulty attaching the tripod collar ring.

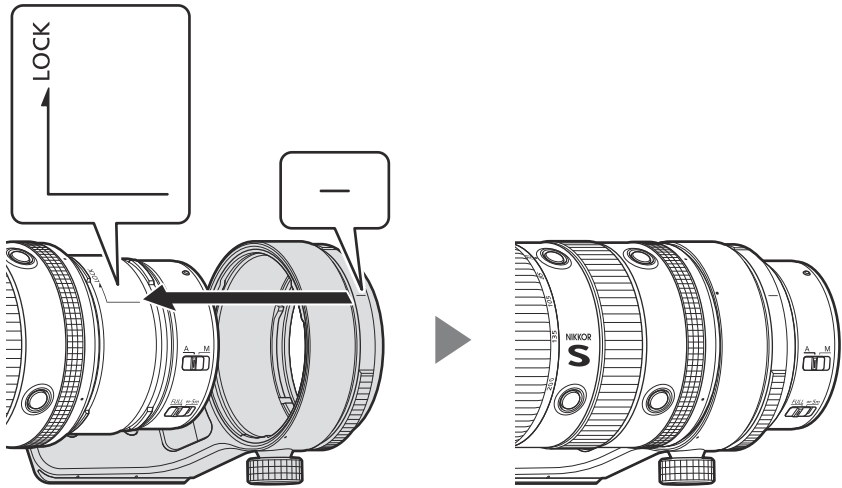

### 3. Rotate the tripod collar ring in the direction shown until it clicks into place.

- Hold the knurled section (non-slip portion) when rotating the tripod collar ring.

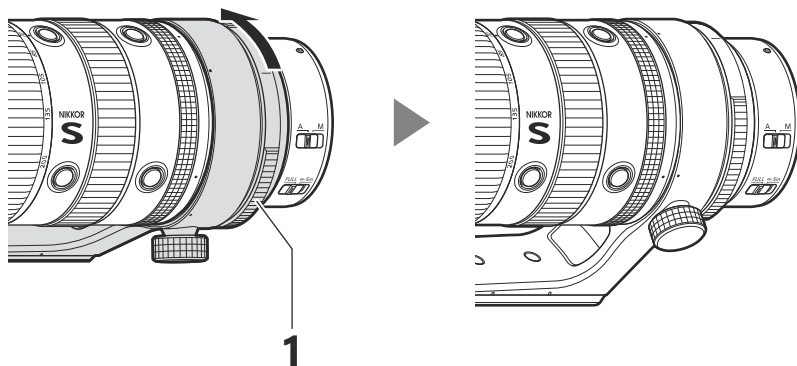

**1** Knurled section (non-slip portion)

## Removing the Tripod Collar Ring

1. Confirm that the tripod collar ring attachment screw on the tripod collar ring is fully tightened.

2. Press and hold the tripod collar ring release button (1) while rotating the tripod collar ring in the direction shown (2) until it stops and remove it from the lens (3).

- Hold the knurled section (non-slip portion) when rotating the tripod collar ring.
- Loosen the tripod collar ring attachment screw if you have difficulty removing the tripod collar ring.

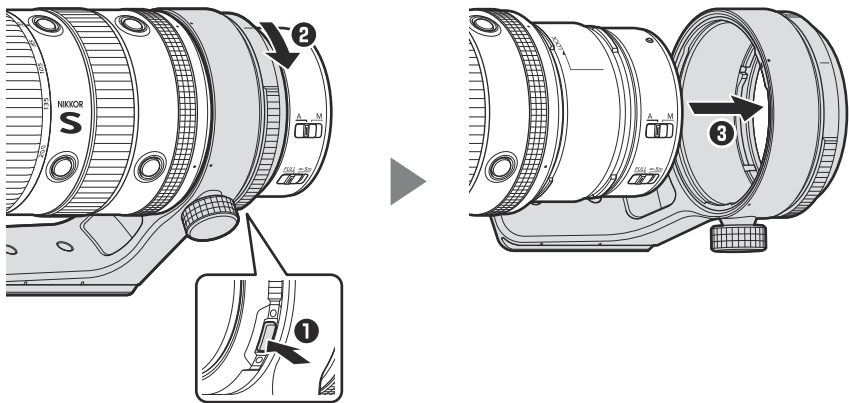

Attach the protective cover to protect the tripod collar ring mount when the tripod collar ring is removed from the lens.

# Protective Cover

## Attaching the Protective Cover

Align the indices on the protective cover and the lens as shown and attach the protective cover to the lens (1). Next, rotate the protective cover in the direction shown until it clicks into place (2).

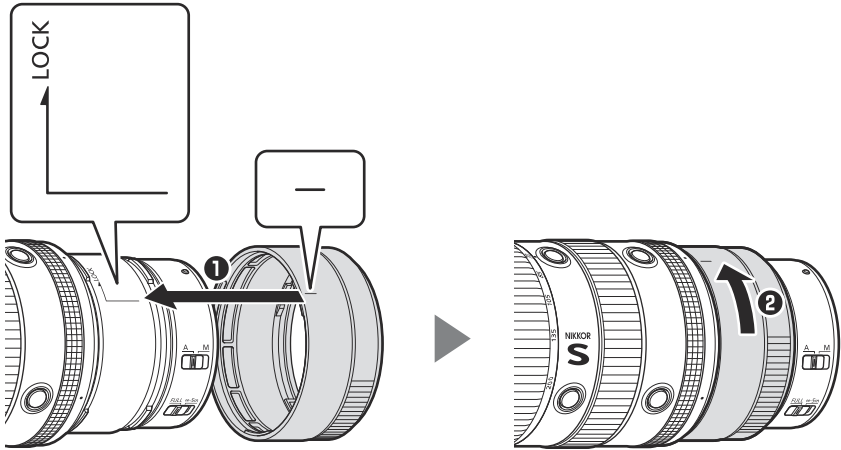

## Removing the Protective Cover

Press and hold the protective cover release button (1) while rotating the protective cover in the direction shown (2) until it stops and remove it from the lens (3).

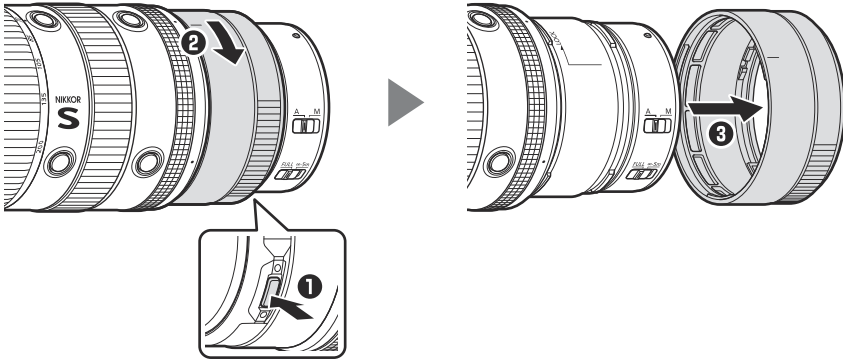

Attach the tripod collar ring to protect the tripod collar ring mount when the protective cover is removed from the lens.

# Attachment and Removal

## Attaching the Lens

1. Turn the camera body off, remove the camera body cap, and detach the rear lens cap.

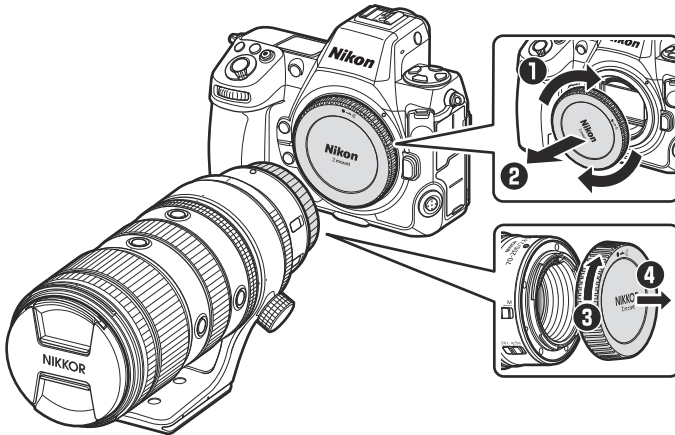

2. Position the lens on the camera body, keeping the mounting mark on the lens aligned with the mounting mark on the camera body (❶), and then rotate the lens in the direction shown (❷) until it clicks into place.

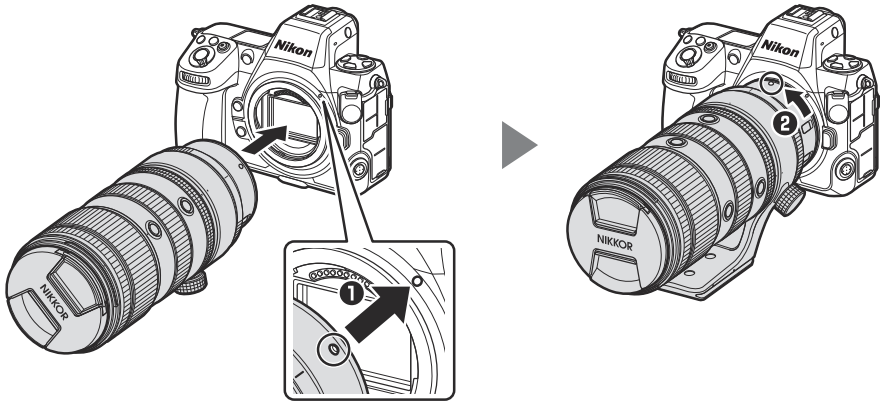

**✓ When the Lens Is Mounted on a Tripod: Attaching the Camera Body**

Position the camera body on the lens, keeping the mounting mark on the lens aligned with the mounting mark on the camera body (1), and then rotate the camera body in the direction shown (2) until the lens clicks into place.

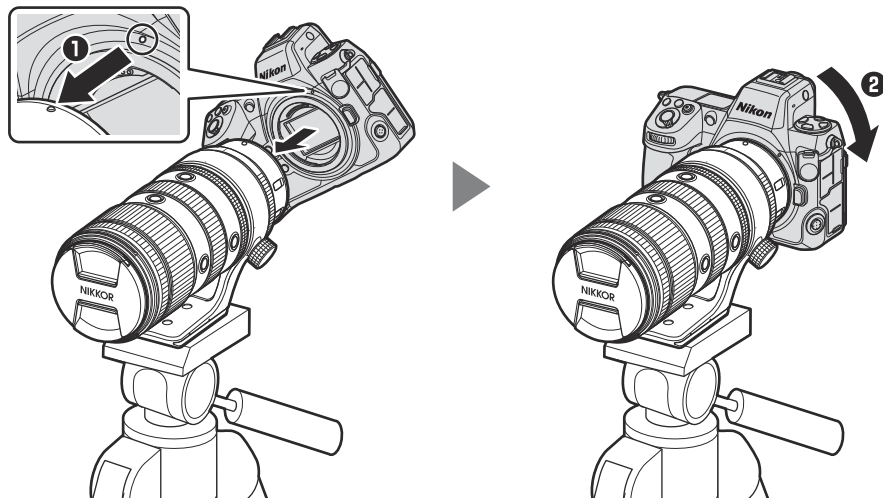

# Removing the Lens

1. Turn the camera body off.

2. Press and hold the lens release button (❶) while turning the lens in the direction shown (❷).

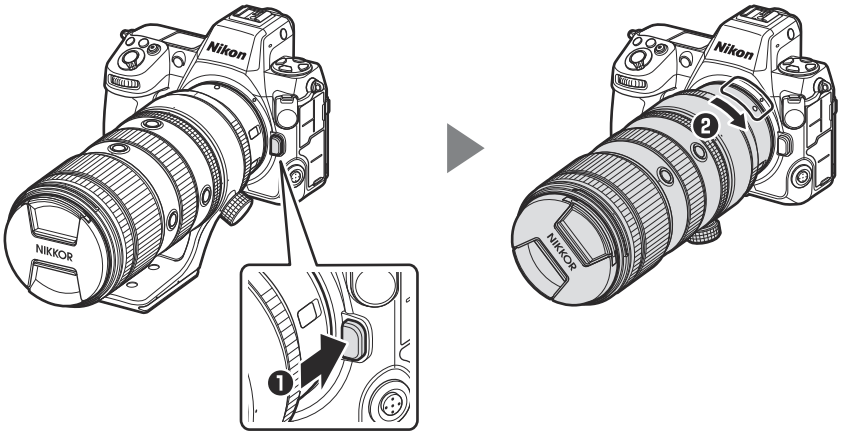

**✓ When the Lens Is Mounted on a Tripod: Removing the Camera Body**

Press and hold the lens release button (1) while turning the camera body in the direction shown (2).

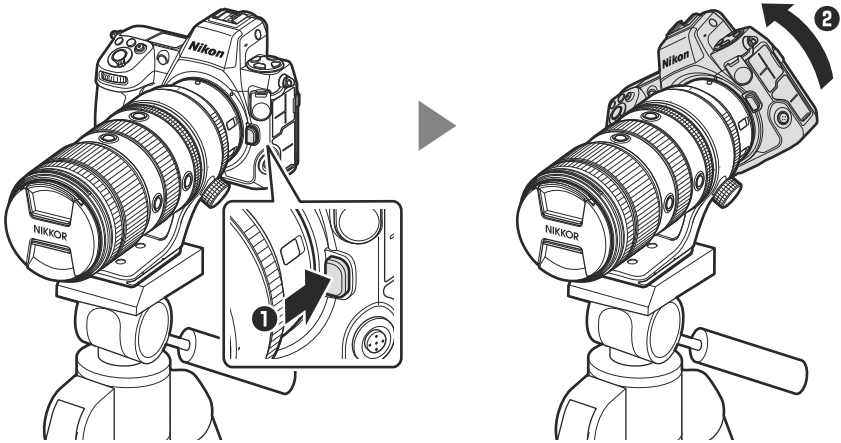

# Using the Lens Hood

This lens hood is equipped with a filter adjustment window. You can rotate a filter such as circular polarizing filters to adjust the effect through this window. Follow the procedure below to attach and remove the lens hood and use the filter adjustment window.

## Attaching the Lens Hood

Align the lens hood alignment mark with the lens hood mounting mark (❶) and then rotate the lens hood in the direction shown (❷) until the mounting mark is aligned with the lens hood lock mark (❸).

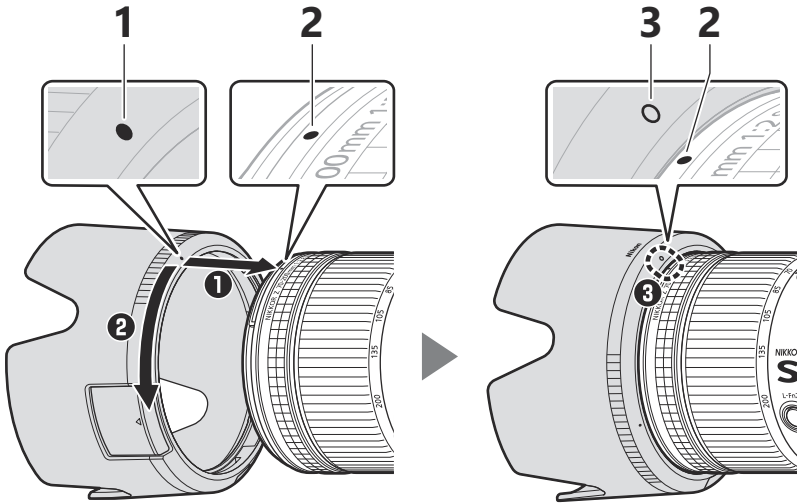

- ❶ Lens hood alignment mark
- ❷ Lens hood mounting mark
- ❸ Lens hood lock mark

- The lens hood can be reversed and mounted on the lens when not in use.

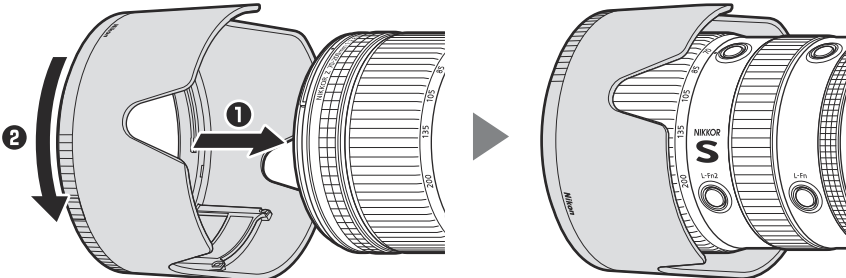

## Removing the Lens Hood

Keeping the lens hood lock release button pressed (❶), rotate the lens hood in the direction shown (❷) and remove it from the lens (❸).

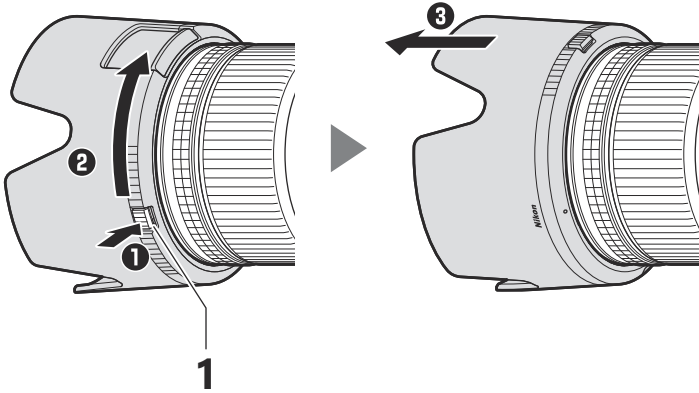

**1** Lens hood lock release button

- The same procedure can be used when the lens hood is reversed.

## Using the Filter Adjustment Window

Open the filter adjustment window by sliding the lever in the direction shown to adjust the filter.

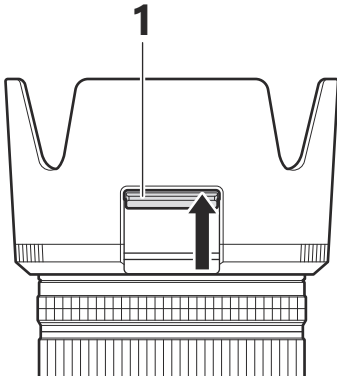

**1** Filter adjustment window

- If the filter adjustment window is left open during shooting, stray light will enter the lens, causing ghosts or flares. We recommend that you close the filter adjustment window when not adjusting the filter.
- Depending on the shape of the filter, it may be difficult to rotate it through the filter adjustment window.

# Using the Tripod Collar Ring

- Ensure that the tripod collar ring is correctly attached to the lens while in use. Failure to do so could cause the lens to detach and fall, potentially resulting in injury or product malfunction.

 [“Attaching and Removing the Tripod Collar Ring and Protective Cover”](#)  
(p.21)

- Attach tripods to the lens tripod collar, not to the camera.

## Rotating the Camera

Attaching tripods to the lens tripod collar rather than to the camera allows the camera to be rotated as described below to take pictures in "tall" or "wide" orientation while a tripod is attached.

### 1. Loosen the tripod collar ring attachment screw (1).

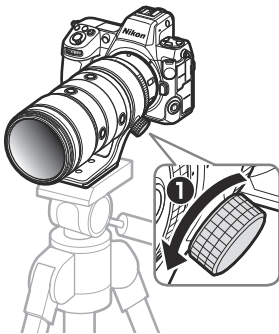

**2. Rotate the camera, using the rotation indices for reference (2).**

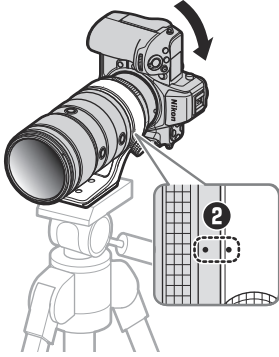

**3. Tighten the tripod collar ring attachment screw (3).**

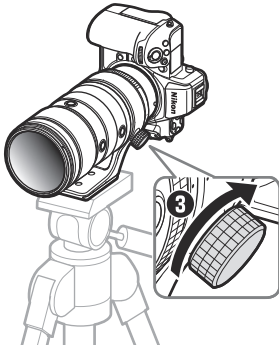

## **Using Arca-Swiss Quick-Release Clamps**

The tripod collar of this lens can be attached to Arca-Swiss screw-type quick-release clamps. Observe the following precautions to prevent injury or product malfunction caused by the lens falling.

- Do not use lever-type clamps, as they may not fix the lens firmly in place.
- Ensure that the clamp knob is fully tightened and the screw-type quick-release clamp is fixed firmly on the tripod collar when using this type of clamp with the lens.

# Vibration Reduction (VR)

The lens supports vibration reduction. Vibration reduction settings can be adjusted from the camera. See the documentation provided with the camera for details.

Vibration reduction allows shutter speeds slower than would otherwise be the case, expanding the range of shutter speeds available.

## Vibration Reduction

- Due to the design of the vibration reduction system, the lens may rattle when shaken. This does not indicate a malfunction.
- To reduce blur caused by tripod shake, select **[Normal]** or **[Sport]** for the on-camera vibration reduction option when the camera is mounted on a tripod. Note, however, that depending on the type of tripod and shooting conditions, there may be cases in which **[Off]** is the preferred option.
- **[Normal]** or **[Sport]** is recommended when the camera is mounted on a monopod.

## Note on Zooming with the Zoom Ring

We recommend that you focus after adjusting the zoom. Changes to the zoom after focusing may cause the focus position to shift. This may be particularly noticeable if you quickly rotate the zoom ring.

# Precautions for Use

- Be sure to support the lens when holding the camera. Failure to observe this precaution could damage the lens and camera mounts.
- Do not pick up or hold the lens or camera using only the lens caps or lens hood.
- Keep the CPU contacts clean.
- Should the rubber lens-mount gasket be damaged, cease use immediately and take the lens to a Nikon-authorized service center for repair.
- Reattach the lens caps when the lens is not in use.
- Do not leave the lens in humid locations or in locations in which it may be exposed to moisture. Rusting of the internal mechanism can cause irreparable damage.
- Do not leave the lens next to open flames or in other extremely hot locations. Extreme heat could damage or warp the lens.
- Taking the lens from a warm to a cold environment or *vice versa* may cause damaging condensation inside and outside the lens. Place the lens in a sealed bag or plastic case before taking it across a temperature boundary. The lens can be taken from the bag or case once it has had time to adjust to the new temperature.
- We recommend that you place the lens in its case to protect it from scratches during transport.
- Keep credit cards and other such magnetic storage devices away from the camera and lens. Data stored on the device could be corrupted.

# Lens Maintenance

- Removing dust is normally sufficient to clean the glass surfaces of the lens.
- When cleaning the fluorine-coated front lens element:
  - Smudges, fingerprints, and other oily stains can be removed using a soft, clean cotton cloth or third-party lens cleaning tissue; clean from the center outwards using a circular motion.
  - To remove stubborn stains, wipe gently using a soft cloth lightly dampened with a small amount of distilled water, ethanol, or third-party lens cleaner.
  - Drop-shaped marks may form on fluorine-coated surfaces, which are highly water- and oil-repellent. Such marks can be removed with a dry cloth.
- When cleaning the rear lens element, which is not fluorine-coated:
  - Smudges, fingerprints, and other oily stains can be removed using a soft, clean cotton cloth or third-party lens cleaning tissue lightly dampened with a small amount of ethanol or third-party lens cleaner; clean from the center outwards in a circular motion. Be sure to clean evenly and thoroughly without leaving smears.
- Never use organic solvents such as paint thinner or benzene to clean the lens.
- Neutral Color (NC) filters (available separately) and the like can be used to protect the front lens element.
- Do not store the lens in direct sunlight or with naphtha or camphor moth balls. If the lens will not be used for an extended period, store it in a cool, dry location to prevent mold and rust.

# Technical Notes

## Cameras with AF-Assist Illuminators

The lens or lens hood may block the light from the camera AF-assist illuminator.

- For the information on using the lens with cameras that have built-in AF-assist illuminators, visit the site below.

<https://downloadcenter.nikonimglib.com/>

# Using the Lens on Cameras with a Built-in Flash

Shadows will be visible in photos where light from the built-in flash is obscured by the lens or lens hood. Remove the lens hood before shooting. Note, however, that depending on the distance to the subject and lens focal length, shadows may appear even when the lens hood is removed.

- For information on the subject distances and focal lengths at which shadows will not appear in photos taken with a built-in flash, visit the site below.

<https://downloadcenter.nikonimglib.com/>

# Accessories

## Supplied Accessories

- LC-77B Lens Cap (front cap)
- LF-N1 Lens Cap (rear cap)
- HB-119 Lens Hood
- CL-C3 Lens Case

### Using the Lens Case

- The case is intended to protect the lens from scratches, not from falls or other physical shocks.
- The case is not water resistant.
- The material used in the case may fade, bleed, stretch, shrink, or change color when rubbed or wet.
- Remove dust with a soft brush.
- Water and stains can be removed from the surface with a soft, dry cloth. Do not use alcohol, benzene, thinner, or other volatile chemicals.
- Do not store in locations exposed to direct sunlight or to high temperatures or humidity.
- Do not use the case to clean the monitor or lens elements.
- Be careful that the lens does not fall from the case during transport.

**Material:** Polyester

## Other Compatible Accessories

- 77 mm filters
- Z TELECONVERTER TC-1.4×/TC-2.0×

### **☑ Filters**

- Use only one filter at a time.
- Remove the lens hood before attaching filters.

### **☑ Teleconverters**

Depending on the subject, ambient lighting conditions, and the focus point selected, the camera may be unable to focus using autofocus or the focus indicator for electronic rangefinding may flicker while a teleconverter is attached.

# Specifications

Mount	Nikon Z mount
Focal length	70 – 200 mm
Maximum aperture	f/2.8
Lens construction	18 elements in 16 groups (including 1 ED element, 1 super-ED element, 1 aspherical ED element, 2 aspherical elements, 1 fluorite element, 1 SR element, elements with meso-amorphous and ARNEO coats, and a fluorine-coated front lens element)
Angle of view	FX format: 34°20' – 12°20'
	DX format: 22°50' – 8°
Focal length scale	Graduated in millimeters (70, 85, 105, 135, 200)
Focusing system	Internal focusing system
Vibration reduction	Lens shift using <b>voice coil motors</b> (VCMs)
Minimum focus distance (measured from focal plane)	<ul style="list-style-type: none"><li>• 70 mm zoom position: 0.38 m (1.25 ft)</li><li>• 85 mm zoom position: 0.38 m (1.25 ft)</li><li>• 105 mm zoom position: 0.5 m (1.64 ft)</li><li>• 135 mm zoom position: 0.6 m (1.97 ft)</li><li>• 200 mm zoom position: 0.8 m (2.63 ft)</li></ul>
Maximum reproduction ratio	0.3× (70 mm focal length)
Diaphragm blades	11 (rounded diaphragm opening)
Aperture range	f/2.8 – 22

<b>Focus limit switch</b>	Two positions: FULL ( $\infty - 0.38$ m) and $\infty - 5$ m
<b>Filter-attachment size</b>	77 mm (P = 0.75 mm)
<b>Dimensions (maximum diameter × distance to end of lens from camera lens mount flange)</b>	Approx. 90 mm × 208 mm (3.6 in. × 8.2 in.)
<b>Weight (with tripod collar ring)</b>	Approx. 1180 g (2 lb 9.7 oz)
<b>Weight (with protective cover)</b>	Approx. 1030 g (2 lb 4.4 oz)
<b>Weight (without tripod collar ring and protective cover)</b>	Approx. 998 g (2 lb 3.2 oz)

- Throughout this document, “FX format” and “FX” are used in reference to an angle of view equivalent to that of a 35 mm format (“full frame”) camera and “DX format” and “DX” to an angle of view equivalent to that of an APS-C camera.
- Nikon reserves the right to change the appearance, specifications, and performance of this product at any time and without prior notice.

# Notices

## Notices for Customers in the U.S.A.

This device complies with part 15 of the FCC Rules. Operation is subject to the following two conditions: (1) this device may not cause harmful interference, and (2) this device must accept any interference received, including interference that may cause undesired operation.

### **Federal Communications Commission (FCC) Radio Frequency Interference Statement**

Note: This equipment has been tested and found to comply with the limits for a Class B digital device, pursuant to part 15 of the FCC Rules. These limits are designed to provide reasonable protection against harmful interference in a residential installation. This equipment generates, uses and can radiate radio frequency energy and, if not installed and used in accordance with the instructions, may cause harmful interference to radio communications. However, there is no guarantee that interference will not occur in a particular installation. If this equipment does cause harmful interference to radio or television reception, which can be determined by turning the equipment off and on, the user is encouraged to try to correct the interference by one or more of the following measures:

- Reorient or relocate the receiving antenna.
- Increase the separation between the equipment and receiver.
- Connect the equipment into an outlet on a circuit different from that to which the receiver is connected.
- Consult the dealer or an experienced radio/TV technician for help.

## CAUTIONS

### • Modifications

The FCC requires the user to be notified that any changes or modifications made to this device that are not expressly approved by Nikon Corporation may void the user's authority to operate the equipment.

Nikon Inc., 1300 Walt Whitman Road, Melville, New York 11747-3064, U.S.A.  
Tel.: 631-547-4200

## Notices for Customers in Canada

CAN ICES-003 (B) / NMB-003 (B)

## Notices for Customers in Europe

This symbol indicates that electrical and electronic equipment is to be collected separately.



The following apply only to users in European countries:

- This product is designated for separate collection at an appropriate collection point. Do not dispose of as household waste.
- Separate collection and recycling helps conserve natural resources and prevent negative consequences for human health and the environment that might result from incorrect disposal.
- For more information, contact the retailer or the local authorities in charge of waste management.

