

Remote Controller

Operating Instructions

Before operating the unit, please read this manual thoroughly and retain it for future reference.

RM-IP500
Software Version 2.3

Table of Contents

Introduction

Using This Manual	4
Features	4
Location and Function of Parts	5
Top	5
Rear	10
Side / front	11
Menu Operations	12
Basic menu operations	13

Getting Started

Connections	15
VISCA over IP (LAN) connection	15
VISCA RS-422 (serial) connection	23
Connection with a video switcher	26
Connection with ILME-FR7	27
Using a Setup PC	28
Accessing a remote controller	28
Saving configuration data on a PC (Backup)	29
Restoring using configuration data	29
Updating the firmware	29
About the RM-IP Setup Tool	30
Using the Panel Sheet for ILME-FR7	31

Operations

Turning on the Power	33
Selecting a Camera	34
Selecting a camera when using LAN connection	34
Selecting a camera when using serial connection	34
About the color of camera buttons	34
About the tally input lamp indicators	34
Operating a Camera	35
Pan and tilt control	35
Zoom control	36
Adjusting a Camera (excluding ILME-FR7)	38
Adjusting the focus	38
Adjusting the brightness	38
Backlight compensation (BACKLIGHT)	39
Flicker compensation (FLICKER)	39
Adjusting the white balance	39
Adjusting the black balance	40
Adjusting a Camera (ILME-FR7)	41
Adjusting the focus	41
Adjusting the brightness	41

Adjusting the white balance	43
Adjusting the black balance	43

Recording Video to a Memory Card (ILME-FR7)

Storing the Camera Status (Preset Function)

Recalling stored status	46
Changing the speed of movement between positions	46

Recording the Pan/Tilt/Zoom Operation of a Camera (Trace Function)

Recording the pan/tilt/zoom operation	47
Starting playback of a recorded trace	47

Operating the Camera Setup Menu from the Unit (Camera Menu Operation Mode) (excluding ILME-FR7)

Buttons and knobs used for camera menu operations	48
--	----

Operating with the Screen Display Overlaid on the Camera Image (CAM GUI Operation Mode) (ILME-FR7)

Assigning Functions to Assign Buttons

Recommended Settings for ILME-FR7 Operation

Recommended setting 1	54
Recommended setting 2	55
Recommended setting 3	56
Recommended setting 4	57
Recommended setting 5	58

Setting Specific Functions using Shortcuts (excluding ILME-FR7)

Buttons and knobs used for FUNCTION menu operations	59
Operation using IRIS, GAIN, and SHUTTER buttons	59
Operation using ASSIGN 4, ASSIGN 5, and ASSIGN 6	60

Setting Specific Functions using Shortcuts (ILME-FR7)

Operating the DETAIL level, knee point, or audio input level	61
Operating the iris, ISO/gain, shutter, ND filter, or exposure compensation	61
Operating camera/lens assignable button functions	61

Checking Camera Settings Status (Status Display)

Restoring Factory Default Settings

Default values	63
----------------------	----

Function of Buttons/Knobs in Each Block by Camera Model

Cameras other than ILME-FR7	64
ILME-FR7	66

RM Menu List

OPERATION	68
EXPOSURE	68
WHITE	69
BLACK	69
DETAIL	69
KNEE	69
MATRIX	70
OTHER	70
OPERATION menu support by camera model	71
CONFIG	73
RM SETUP	73
SW ASSIGN	74
DIRECTION	74
GPI I/O	75
LAN	76
SERIAL	76
CONTROL I/F	76
AUTO IP SETUP	76
SETUP IP	76
ASSIGN CAM	76
CLEAR TABLE	76
SWAP CAM	76
MANUAL	76
CAMERA TABLE	77
MAINTENANCE	77
MODEL INFO	77
UPDATE MODE	77
RESET	78
SENSITIVITY	78

Appendix

Troubleshooting	79
Messages Displayed on the LCD Panel ...	80
Warning messages	80
Error messages	80
Specifications	82
Dimensions	82
Pin assignments	83
TALLY/CONTACT connector input connection example	84
TALLY/CONTACT connector output connection example	84
Input waveform of TALLY/CONTACT connector	84
License	85
uIP	85
µT-Kernel2.0	85

- Microsoft, Windows, and Microsoft Edge are trademarks or registered trademarks of Microsoft Corporation in the United States and/or other countries.
- Intel and Core are registered trademarks of Intel Corporation or its subsidiaries in the United States and other countries.
- Google Chrome is a trademark or registered trademark of Google LLC.
- Wi-Fi is a registered trademark of Wi-Fi Alliance.

All other company and product names are trademarks or registered trademarks of the respective companies or their respective makers. Trademarked items are not indicated by ® or ™ symbols in this manual.

Data and security

- SONY WILL NOT BE LIABLE FOR DAMAGES OF ANY KIND RESULTING FROM A FAILURE TO IMPLEMENT PROPER SECURITY MEASURES ON TRANSMISSION DEVICES, UNAVOIDABLE DATA LEAKS RESULTING FROM TRANSMISSION SPECIFICATIONS, OR SECURITY PROBLEMS OF ANY KIND.
- When connecting this product to a network, connect via a system that provides a protection function, such as a router or firewall. If connected without such protection, security issues may occur.
- Do not browse any other website in the Web browser while making settings or after making settings. Since the login status remains in the Web browser, close the Web browser when you complete the settings to prevent unauthorized third parties from using the unit or harmful programs from running.

Introduction

Safety Regulations (Supplied)

Describes the important points for safe use of the unit.
Be sure to read it.

Operating Instructions (This document/ Web)

These operating instructions describe the names of the various parts of the unit, installation, connection, and operation methods.

Panel sheet for ILME-FR7 (supplied)

This is a panel sheet on which the function names are printed for an ILME-FR7 target camera.

Using This Manual

The Operating Instructions is designed to be read on a computer display.
The content you need to know in order to use the unit is described here.
Read it before you operate the unit.

Jumping to a related page

When you read the instructions on a computer display and click on the related part of the relevant page that is being displayed, you jump to the related page. Relevant pages can be searched easily.

Software display examples

The software displays described in this manual are explanatory examples. Note that some displays may be different from the ones that actually appear.

Printing the Operating Instructions

Depending on your system, certain displays or illustrations in the Operating Instructions, when printed out, may differ from those that appear on your screen.

Terminology in this document

The RM-IP500 is referred to as the "unit" or "remote controller" in this document.

Features

This unit is a remote controller that provides the full functionality and operability of Sony PTZ cameras.

Simple system construction

The unit can be used to control up to 100 cameras connected via LAN connection using switching hubs.

You can build a system, using the setup functions of the unit, to set the IP address and camera number of multiple cameras in a single step, without using a setup PC.

Functional design

The buttons and knobs of the control panel are grouped by type of operation for easy operation. For example, the buttons and knobs for making color adjustments on a camera are grouped together in the color adjustment block.

Compact size

The unit has a compact size for mounting on a desktop. It can also be mounted in a console desk.

Flexible camera operation for various use cases

You can adjust the pan, tilt, and zoom of the camera image with one hand using a joystick. The zoom operation can also be controlled using a zoom lever, enabling detailed camera control using both hands.

The speed of pan, tilt, and zoom can also be adjusted using a speed adjustment knob.

Preset memory function

You can save camera settings, such as pan/tilt/zoom positions and other camera adjustment settings, in the memory of the camera. The stored settings can be recalled and applied to the camera by pressing a preset number button assigned when storing settings.

Simple operation of various camera adjustments

Using the buttons on the unit, you can quickly control various camera functions, such as auto focusing, one-push auto focus, AE (Auto Exposure) function, one-push auto white balance, and backlight compensation, without having to access the camera menu.

Location and Function of Parts

The functions controlled by the buttons and knobs switch automatically depending on the target camera to control. For details about operation for each function, see "Function of Buttons/Knobs in Each Block by Camera Model" (page 64).

Top

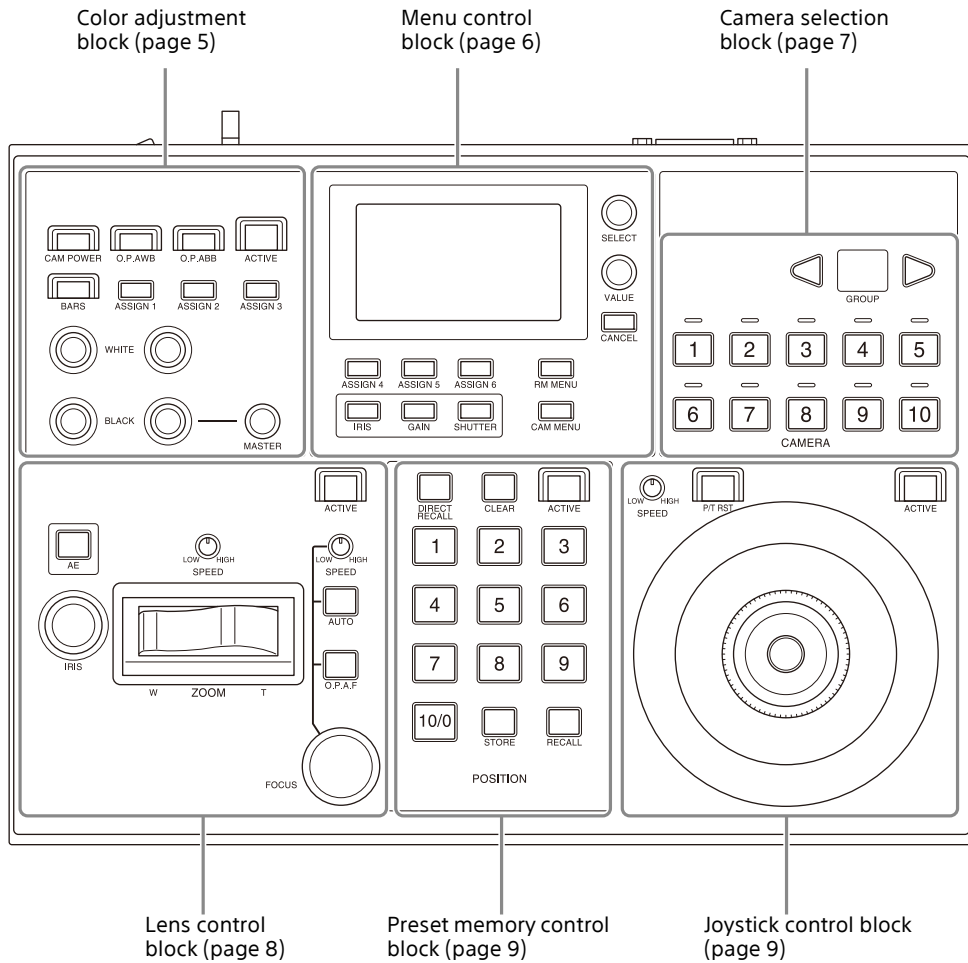

Color adjustment block

Use to perform color adjustments on a camera. Select the target camera to adjust the color. The color adjustment block is enabled when the **7** ACTIVE button is lit. For details about selecting the target camera, see "Selecting a Camera" (page 34).

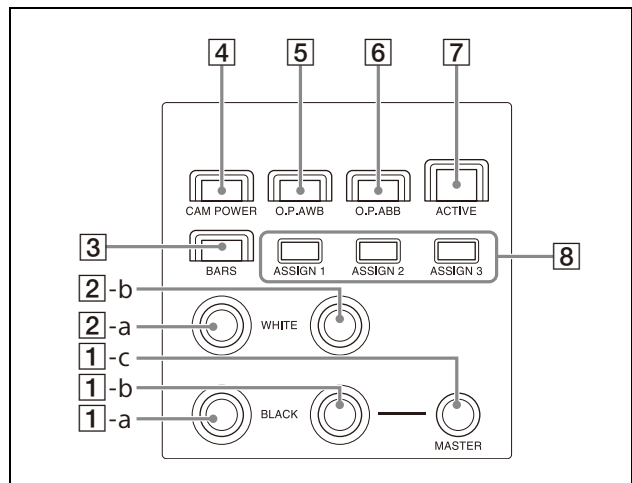

- 1 1-a R-BLACK knob**
1 1-b B-BLACK knob
1 1-c MASTER BLACK knob
 Adjusts the R black, B black, and master black of the target camera.
 For details, see "Adjusting the black balance" (page 40).
- 2 2-a R-WHITE knob**
2 2-b B-WHITE knob
 Sets the R gain and B gain of the target camera, and adjusts the white balance.
 For details, see "Adjusting the white balance" (page 39).
 For an ILME-FR7 target camera, you can also adjust the white balance by settings the color temperature and tint.
 For details, see "Adjusting the white balance" (page 43).
- 3 BARS button**
 Toggles the color bars output of the target camera on/off.
 When the button is turned on (button is lit yellow), color bars output is turned on.
 When the button is turned off (button is not lit), color bars are not output.
- 4 CAM POWER button**
 Toggles the power supply of the target camera on/off (standby).
 When the button is turned on (button is lit green), the target camera is turned on.
 When the button is turned off (button is not lit), the target camera is turned off (standby).

Notes

- When controlling more than one camera, the camera on/off operation is determined by the CONFIG >RM SETUP >CAM POWER setting in the RM menu. For details, see "CAM POWER" (page 74).
- SRG-300SE, SRG-301SE, and SRG-201SE do not turn off (standby).

- 5 O.P.AWB (one-push auto white balance) button**
 Executes one-push auto white balance adjustment on the target camera.
 For details, see "To adjust the white balance automatically" (page 40).
- 6 O.P.ABB (one-push auto black balance) button (excluding ILME-FR7)**
 Executes one-push auto black balance adjustment on the target camera.

For details, see "To adjust the black balance automatically" (page 40).

REC START/STOP button (ILME-FR7)

Starts/stops recording video to the memory card inserted in the camera.

- 7 ACTIVE button**
 Enables/disables the color adjustment block.
 When the button is turned on (button is lit), the color adjustment block becomes enabled.
 When the button is turned off (button is not lit), the color adjustment block becomes disabled.
- 8 ASSIGN 1 button, ASSIGN 2 button, ASSIGN 3 button**
 Executes functions assigned to each button. When a button is pressed, the name of the function assigned to the button is displayed highlighted on the bottom of the LCD panel for a few seconds.
 For details about assigned functions and how to assign the functions, see "Assigning Functions to Assign Buttons" (page 51).

Menu control block

Comprises buttons and knobs you use to set and execute functions, and to change settings on the target camera using menu operations.

For details about menu operations, see "Menu Operations" (page 12).

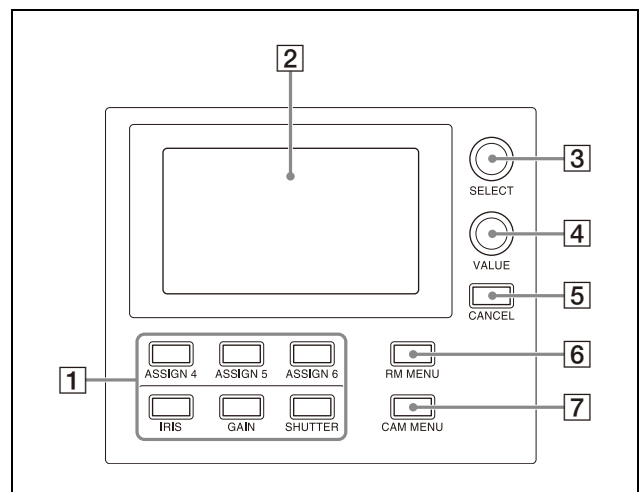

- 1 FUNCTION menu buttons**
 When a button is pressed, the item and setting of the function assigned to the button is displayed on the LCD panel, and the setting can be changed using the VALUE knob.

For a target camera other than an ILME-FR7, the IRIS, GAIN, and SHUTTER button operations are enabled when the buttons are lit blue.

For details about functions that can be assigned to the ASSIGN 4 to ASSIGN 6 buttons and how to assign the functions, see "Assigning Functions to Assign Buttons" (page 51).

For details about operation, see "Setting Specific Functions using Shortcuts (excluding ILME-FR7)" (page 59) or "Setting Specific Functions using Shortcuts (ILME-FR7)" (page 60).

For an ILME-FR7 target camera, the setup items and values for some functions are displayed overlaid on the camera image and not on the LCD of the unit.

2 LCD panel

Displays the RM menu, FUNCTION menu, and preset memory numbers.

- For details about menu operations, see "Menu Operations" (page 12).
- For details about the RM menu, see "RM Menu List" (page 68).
- For details about the FUNCTION menu, see "Setting Specific Functions using Shortcuts (excluding ILME-FR7)" (page 59) or "Setting Specific Functions using Shortcuts (ILME-FR7)" (page 60).
- For details about preset numbers, see "Storing the Camera Status (Preset Function)" (page 45).

3 SELECT knob and button

Use to select menu items.

For details about menu operations, see "Menu Operations" (page 12).

4 VALUE knob and button

Use to select the settings of menu items.

For details about menu operations, see "Menu Operations" (page 12).

5 CANCEL button

Use to move from a lower level to a higher level in the hierarchy for menu items that have a multi-level hierarchy.

6 RM MENU button

Press this button to display the setup menu of the unit on the LCD panel.

For details about menu operations, see "Menu Operations" (page 12).

7 CAM MENU button

Press and hold this button to display the setup menu of the camera on the monitor output of the camera. Nothing is displayed on the LCD panel of the unit.

For details about operation, see "Operating the Camera Setup Menu from the Unit (Camera Menu Operation Mode) (excluding ILME-FR7)" (page 48) or "Operating with the Screen Display Overlaid on the Camera Image (CAM GUI Operation Mode) (ILME-FR7)" (page 50).

Camera selection block

Use to select the target camera to control.

When using LAN connection, the unit can control up to 100 cameras.

When using serial connection, the unit can control up to 7 cameras.

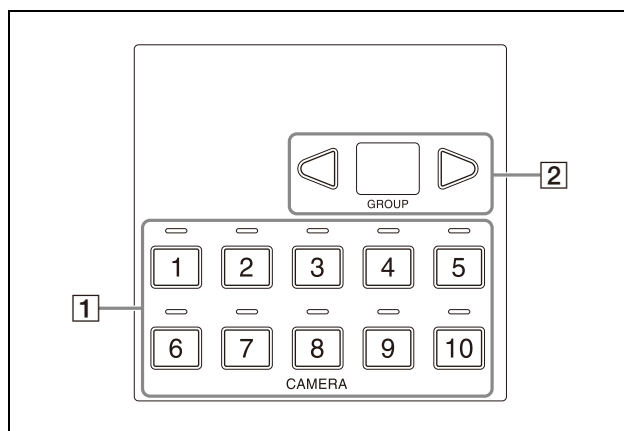

1 CAMERA 1 to CAMERA 10 buttons, CAMERA 1 to CAMERA 10 tally input lamps

Selects the target camera from within a group.

For details about selecting the target camera, see "Selecting a Camera" (page 34). When a camera selected by an external device, such as a switcher, is outputting a tally signal, the tally input lamp on the top of the corresponding camera button lights up. For details about tally input lamps, see "About the tally input lamp indicators" (page 34).

2 GROUP LEFT button, group number display, GROUP RIGHT button

Select the target camera group using the GROUP LEFT button and GROUP RIGHT button. The number of the selected group is displayed in the group number display. Group numbers are used with LAN connections.

For details about selecting a group, see “Selecting a Camera” (page 34).

Lens control block

Use to control the lens (adjustment and settings) of the target camera.

The lens control block is enabled when the **5** ACTIVE button is lit. Note that the ZOOM SPEED knob is always enabled.

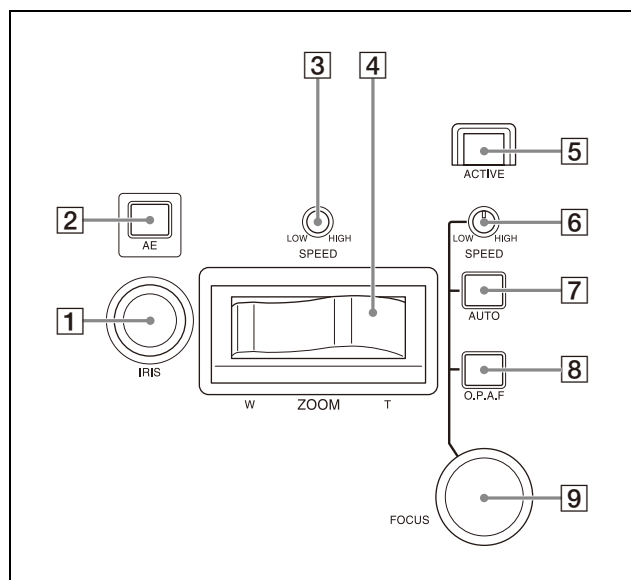

1 IRIS knob

Adjusts the iris of the target camera. For details, see “To adjust the exposure manually” (page 38). For an ILME-FR7 target camera, you can also assign ND filter adjustments (page 41).

2 AE button

For a target camera other than an ILME-FR7, switches the exposure mode of the target camera. When turned on (button is lit), automatic adjustment mode is selected. When turned off (button is not lit), the exposure mode set using AE CONFIG in the RM menu is selected. For an ILME-FR7 target camera, when the button is turned on (button is lit), the exposure mode set using AE CONFIG2 in the RM menu is selected. When the button is turned off (button is not lit), manual adjustment mode is selected. For details, see “To adjust the exposure automatically” (page 38).

3 ZOOM SPEED knob

Sets the speed of zoom operations. For details, see “To control the zoom using the ZOOM lever on the lens control block” (page 37).

4 ZOOM lever

Controls the zoom operation of the target camera. For details, see “To control the zoom using the ZOOM lever on the lens control block” (page 37).

5 ACTIVE button

Enables/disables the lens control block. When the button is pressed, turning it on (button is lit), the lens control block becomes enabled. When the button is turned off (button is not lit), the lens control block becomes disabled except for the ZOOM SPEED knob operation.

6 FOCUS SPEED knob

Sets the focus speed when adjusting the focus manually. For details, see “To adjust the focus manually” (page 38).

7 AUTO FOCUS mode button

Switches between automatic (button is lit) and manual (button is not lit) focus adjustment mode on the target camera. For details, see “To adjust the focus automatically” (page 38).

8 O.P.A.F (one-push auto focus) button

For a target camera other than an ILME-FR7, press during manual focus adjustment mode to execute one-push auto adjustment. For details, see “One-push auto focus during manual focus adjustment” (page 38). For an ILME-FR7 target camera, it becomes a Push AF/Push MF button. While the button is pressed, it operates in the adjustment mode opposite to the focus adjustment mode set by the AUTO FOCUS mode button. For example, it performs automatic adjustment while the button is pressed in manual adjustment mode. For details, refer to the Help Guide of the camera.

9 FOCUS adjustment knob

Adjusts the focus of the target camera manually. For details, see “To adjust the focus manually” (page 38).

Preset memory control block

Use to execute the Preset function for storing and recalling camera status (such as pan, tilt, zoom position settings) in internal memory on the camera.

The preset memory control block is enabled when the **4** ACTIVE button is lit.

Note

The number of presets varies depending on the model and firmware version of the camera. For details, refer to the operating instructions for the camera.

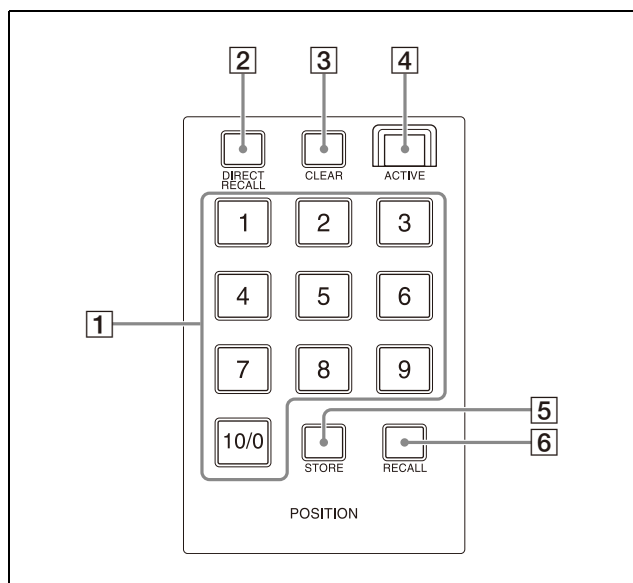

- 1 PRESET 1 button to PRESET 10/0 button**
Use to enter the number (preset number) for registering and recalling a preset camera status.
For details, see “Storing the Camera Status (Preset Function)” (page 45).
- 2 DIRECT RECALL button**
Recalls a preset stored in the target camera. Direct recall mode is enabled when the button is lit. Press PRESET 1 to PRESET 10/0 to recall the stored settings immediately.
For details, see “Storing the Camera Status (Preset Function)” (page 45).
- 3 CLEAR button**
Clears the currently entered preset number. Pressing and holding the CLEAR button cancels the recall operation and stops the camera at its current position.
- 4 ACTIVE button**
Enables/disables operation of the preset memory control block.

When the button is turned on (button is lit), the preset memory control block becomes enabled.

When the button is turned off (button is not lit), the preset memory control block becomes disabled.

- 5 STORE button**
Stores the camera status in the internal memory of the camera for the specified preset number.
For details, see “Storing the Camera Status (Preset Function)” (page 45).

- 6 RECALL button**
Recalls a preset stored in the target camera.
For details, see “Recalling stored status” (page 46).

Joystick control block

Use to control the pan, tilt, and zoom of the target camera using a joystick.

The joystick control block is enabled when the **4** ACTIVE button is lit.

Select the target camera to control the pan, tilt, and zoom using a joystick.

For details about camera pan, tilt, and zoom operations, see “Pan and tilt control” (page 35).

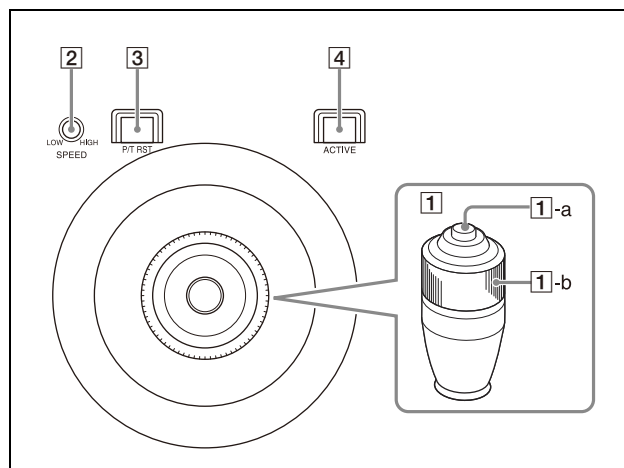

- 1 Joystick**
Controls the pan, tilt, and zoom operation of the target camera.
Pan/tilt: Incline the joystick left/right to rotate the camera counterclockwise/clockwise (pan left/right), incline the joystick forward/backward to tilt the camera up/down. The panning/tilting speed changes according to the angle at which you incline the joystick. Movement stops when the joystick returns to the center position (position the joystick returns to after removing your hand).

Zoom: Turn the ZOOM ring on the upper part of the joystick clockwise to make the subject larger (zoom in). Turn it counterclockwise to make the subject smaller (zoom out).

For an ILME-FR7 target camera, you can switch the joystick function to the screen display operation on the camera image using the CAM GUI / P/T RST (pan/tilt reset) button. For details, see "Operating with the Screen Display Overlaid on the Camera Image (CAM GUI Operation Mode) (ILME-FR7)" (page 50).

1-a Joystick button

Press and hold to return the orientation of the camera to face the front.

For an ILME-FR7 target camera, it functions as the apply button in CAM GUI operation mode.

1-b ZOOM ring

Controls the zoom.

For details, see "To control the zoom using the ZOOM ring on the top of the joystick" (page 36).

2 PAN-TILT SPEED knob

Adjusts the speed of pan/tilt operations in response to the joystick.

For details, see "To adjust the pan/tilt speed" (page 35).

3 CAM GUI / P/T RST (pan/tilt reset) button

Press and hold the button to reset the pan/tilt position of the target camera.

For an ILME-FR7 target camera, press the button to switch the joystick function as follows.

Button state	Function
Not lit	Pan and tilt control
Lit	Screen display operation overlaid on the camera image. (CAM GUI operation mode)

4 ACTIVE button

Enables/disables operation of the joystick control block.

When the button is turned on (button is lit), operation of the joystick control block becomes enabled.

When the button is turned off (button is not lit), operation of the joystick control block becomes disabled.

Rear

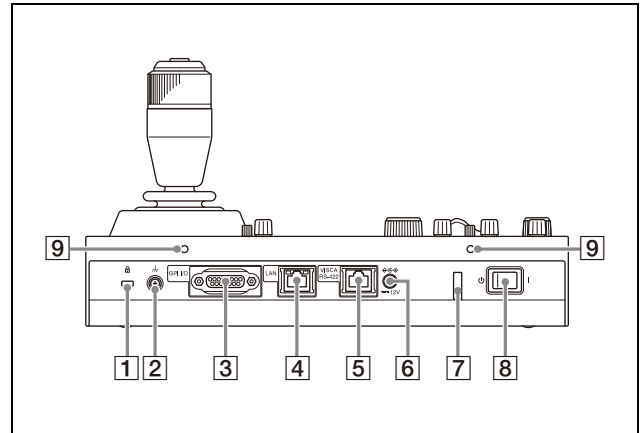

1 **Anti-theft wire attachment point**
Attach a wire to prevent theft.

2 **Ground connection**

3 **GPI I/O connector**
Used as a tally input from an external device or as a contact output connector of the selected camera number.

4 **LAN (network) connector (RJ-45)**
Use for LAN connection.
Connect a LAN hub (10BASE-T/100BASE-TX) using a LAN cable (category 5 or higher). When a link is established, the green indicator lights, and it blinks during communication. For 100BASE-TX connections, the yellow indicator lights.

Notes

- For safety, do not connect the connector for peripheral device wiring that might have excessive voltage to this port. Follow the instructions for this port.
- When you connect the LAN cable of the unit to peripheral device, use a shielded-type cable to prevent malfunction due to radiation noise.

5 **VISCA RS-422 OUT connector (RJ-45)**
Used for VISCA RS-422 serial connection.

6 **12 V (DC power supply input) connector**
Connect to an AC power adapter (sold separately).

7 Cord clamber

Clamp the cord of the AC power adapter to prevent the cord from being pulled out of the unit.

- 1 Release the lock of the cord clamber.
- 2 Connect an AC power adapter.

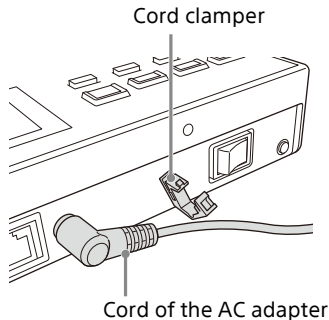

- 3 Thread the cord of the AC power adapter through the cord clamber, then close the lock.

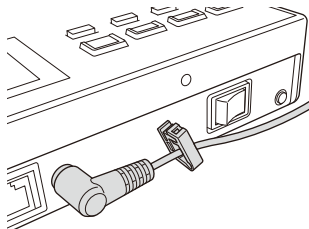

8 Power switch

Turns the power I (on) and ⏻ (off).

Note

When the unit is mounted in a control console, turn the power on/off using the main power supply of the console desk.

9 Screw holes

Mounting points available for use when not mounting the unit on a flat surface. Screw holes are provided on all sides, with the screw holes on the front, left, and right sides protected by covers (six locations).

Side / front

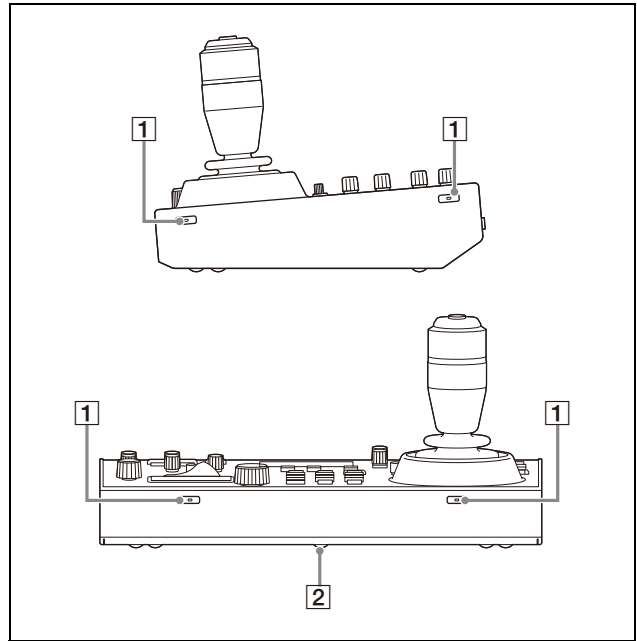

1 Screw hole protective covers

When mounting the unit on other than a flat surface, remove the screw hole protective covers and secure the unit in place with screws.

There are a total of six covers on the front, left, and right sides.

Notes

- Use standard size screws with the following dimensions.

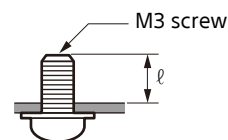

ℓ (contact surface to end of thread) = 6 mm to 10 mm

- Do not overtighten the screws. Overtightening the screws may damage the unit.
- Store the removed screw hole protective covers in a safe location.
- Using screws with length other than 6 mm to 10 mm may result in faulty installation or damage to the interior of the machine, resulting in malfunction.

Removing the screw hole protective covers

- 1 Bend the tip of a thin rod about 2 mm, and insert it into the hole of the screw hole protective cover.**

Use a paper clip or other object with a diameter of about 1 mm.

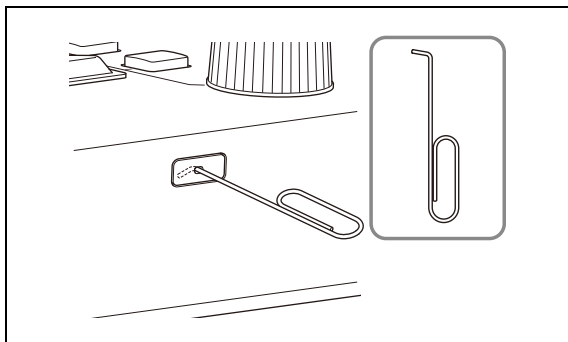

- 2 Pull the screw hole protective covers straight out.**

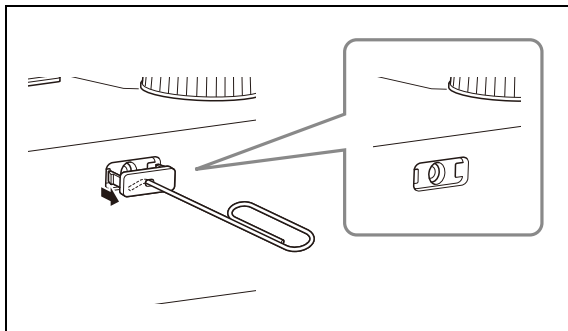

- 2 Ratings label (bottom)**
Displays the model name and electrical ratings information.

Important

The nameplate is located on the bottom.

Menu Operations

The menu control block is used to configure the device settings and camera settings.

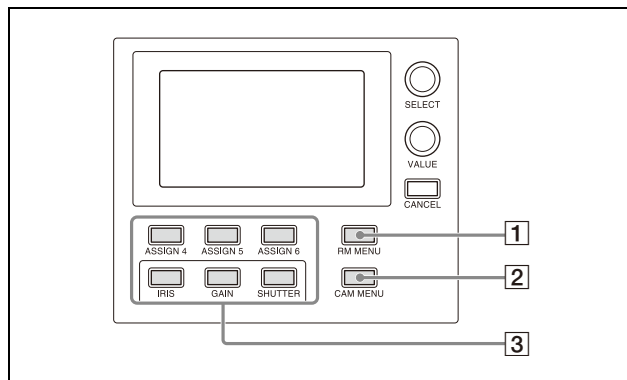

One of the three menus (RM menu, camera menu, or FUNCTION menu) is always selected. When the RM menu or FUNCTION menu is selected, the menu items and settings are displayed on the LCD panel. When the camera menu is selected, nothing is displayed on the LCD panel.

- 1 RM menu**
This menu is used to configure picture quality adjustments and compensation functions on target cameras, configure the unit, execute/configure auto assign functions on cameras, and for performing configuration from a connected setup PC. When the RM MENU button is turned on, RM menu setup mode is invoked and the top menu is displayed on the LCD panel. For details, see "RM Menu List" (page 68).
- 2 Camera menu**
Turns the superimposed output of the camera setup menu on the camera image on/off. When turned on, operation of the setup menu on the camera using the knobs and buttons on the menu control block and the joystick is enabled. For details, see "Operating the Camera Setup Menu from the Unit (Camera Menu Operation Mode) (excluding ILME-FR7)" (page 48).
For an ILME-FR7 target camera, it can be operated using the knobs and buttons on the menu control block. For details about joystick operations, see "Operating with the Screen Display Overlaid on the Camera Image (CAM GUI Operation Mode) (ILME-FR7)" (page 50).

3 FUNCTION menu

This menu is used to configure functions assigned to buttons using shortcuts. For details, see “Setting Specific Functions using Shortcuts (excluding ILME-FR7)” (page 59). For an ILME-FR7 target camera, see “Setting Specific Functions using Shortcuts (ILME-FR7)” (page 60).

Basic menu operations

Buttons and knobs used for RM menu operations

Operation	Buttons and knobs used	
	OPERATION menu	CONFIG, AUTO IP SETUP, or MAINTENANCE menu
Display the top menu.	Press the RM MENU button.	
Select a top menu item.	Turn the SELECT knob.	
Confirm the menu item selection.	Press the SELECT button.	
Select a setup menu item.	Turn the SELECT knob.	
Confirm the setup menu item selection.	Press the SELECT button.	
Select a setup menu sub item.	Turn the SELECT knob.	
Change the setting of the setup menu sub item.	Turn the VALUE knob.*1	
Confirm the changed setting.	Confirmation not required.	Press the VALUE button.*1
Save settings.	Saved on the camera using the camera preset memory function.*3	Save on the unit.
Go back one level in the menu.	Press the CANCEL button.	Press the CANCEL button.*2

*1 A confirmation message appears for settings that display an EXEC item.

*2 If the CANCEL button is pressed before attempting to save, the menu display goes back one level and restores the existing setting.

*3 For details about items saved with a preset number, refer to the operating instructions for each camera.

Typical RM menu operation

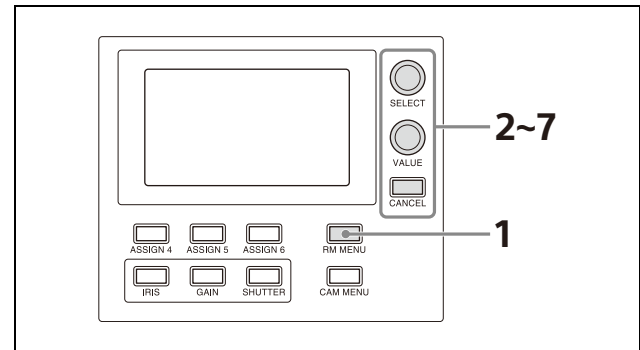

1 Press the RM MENU button, turning it on (button is lit yellow).
The RM menu top menu appears.

2 Turn the SELECT knob to move the cursor to the desired item to set.
The cursor moves up/down as the SELECT knob is turned.

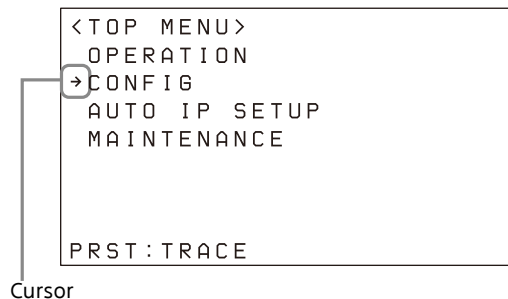

Cursor

3 Press the SELECT button.
The menu for the selected item appears.

4 Turn the SELECT knob to move the cursor to the desired setup menu item.
The cursor moves up/down as the SELECT knob is turned.

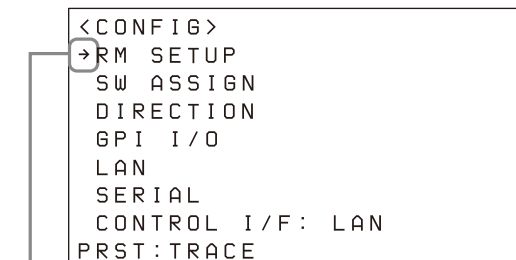

Cursor

5 Press the SELECT button.
The selected menu item and its setup items appear.

6 Turn the SELECT knob to move the cursor to the desired item.

The cursor moves up/down as the SELECT knob is turned.

7 Turn the VALUE knob to select the setting.

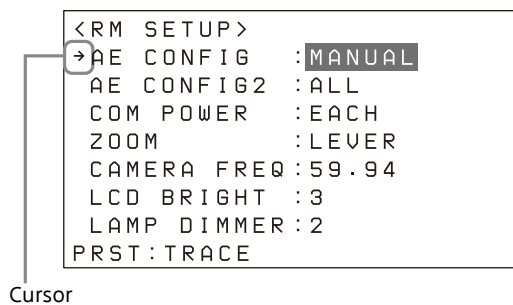

For items that require confirmation after the setting is changed, the current selection is displayed highlighted.

Press the VALUE button to apply the change. The highlight display disappears.

To configure items in other menus

Press the CANCEL button to return to the parent item in the menu, and then use the same procedure.

Getting Started

Connections

You can connect the unit to cameras using VISCA over IP (LAN) connection or VISCA RS-422 (serial) connection.

The connection method that is used is displayed at the bottom of the CONFIG menu item in the RM menu.

VISCA over IP (LAN) connection

```
<CONFIG>
RM SETUP
SW ASSIGN
DIRECTION
GPI I/O
LAN
SERIAL
CONTROL I/F: LAN
PRST: TRACE
```

VISCA RS-422 (serial) connection

```
<CONFIG>
RM SETUP
SW ASSIGN
DIRECTION
GPI I/O
LAN
SERIAL
CONTROL I/F: SERIAL
PRST: TRACE
```

- For details about VISCA over IP (LAN) connection, see "VISCA over IP (LAN) connection" (page 15).
- For details about VISCA RS-422 (serial) connection, see "VISCA RS-422 (serial) connection" (page 23).

For details about connections, refer to the operating instructions for each camera.

VISCA over IP (LAN) connection

VISCA over IP (LAN) connection is configured using the following sequence.

Setting the IP address of the unit (page 15)



Connecting remote controllers, cameras, and setup PC using LAN connection (page 17)



Assigning cameras (page 18)

- Assignment using AUTO IP SETUP >SETUP IP (page 18)
- Assignment using AUTO IP SETUP >ASSIGN CAM (page 19)

Setting the IP address of the unit

Before connection, set the IP address of the unit. The setting is configured using CONFIG >LAN in the RM menu.

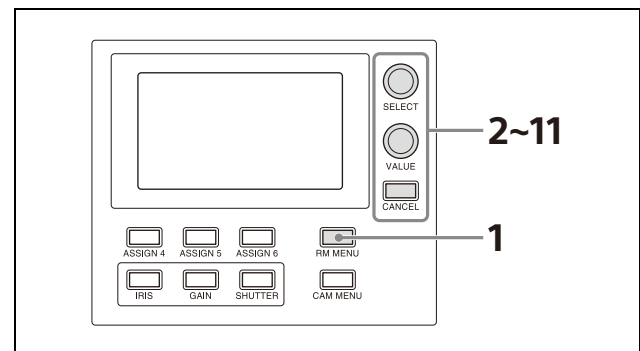

- 1 Press the RM MENU button, turning it on (button is lit yellow).**
The RM menu top menu appears.
- 2 Turn the SELECT knob to move the cursor to CONFIG.**
- 3 Press the SELECT button.**
The CONFIG menu appears.

4 Turn the SELECT knob to move the cursor to LAN, and press the SELECT button.

The LAN menu appears.

```
<LAN>
IP: →192. 168. 0. 10
SM: 255. 255. 255. 0
GW: 0. 0. 0. 0
APPLY      : NOT EXEC

MAC: xx-xx-xx-xx-xx-xx
PRST: TRACE
```

The MAC address is displayed at the bottom of the screen.

5 Turn the SELECT knob to move the cursor to the first 3 digits of IP.

6 Set the IP address using the SELECT knob and VALUE knob/button.

The default setting is 192.168.0.10.

① **Turn the SELECT knob clockwise to move the cursor to the first three digits (for example, 192).**

```
IP: →192. 168. 0. 10
```

② **Turn the VALUE knob to set the value.**
Turning clockwise increases the value, and turning counterclockwise decreases the value.

③ **Turn the SELECT knob to move to the next number and repeat step ② to set the other numbers.**

7 Set SM (subnet mask) and GW (default gateway address) in the same way as described in steps 5 and 6.

8 When finished making all settings, move the cursor to APPLY.

9 Turn the VALUE knob to change NOT EXEC to EXEC, then press the VALUE button.

A "WAIT FOR A FEW SECONDS" message is displayed on the screen.

10 When the message disappears, turn the VALUE knob to change NO to YES, then press the VALUE button.

```
<CONFIRM EXECUTION>
→CONFIRM      : YES
```

The unit reboots automatically.

Upon rebooting, the IP address setting is completed.

Connecting remote controllers, cameras, and setup PC using LAN connection

Connection example

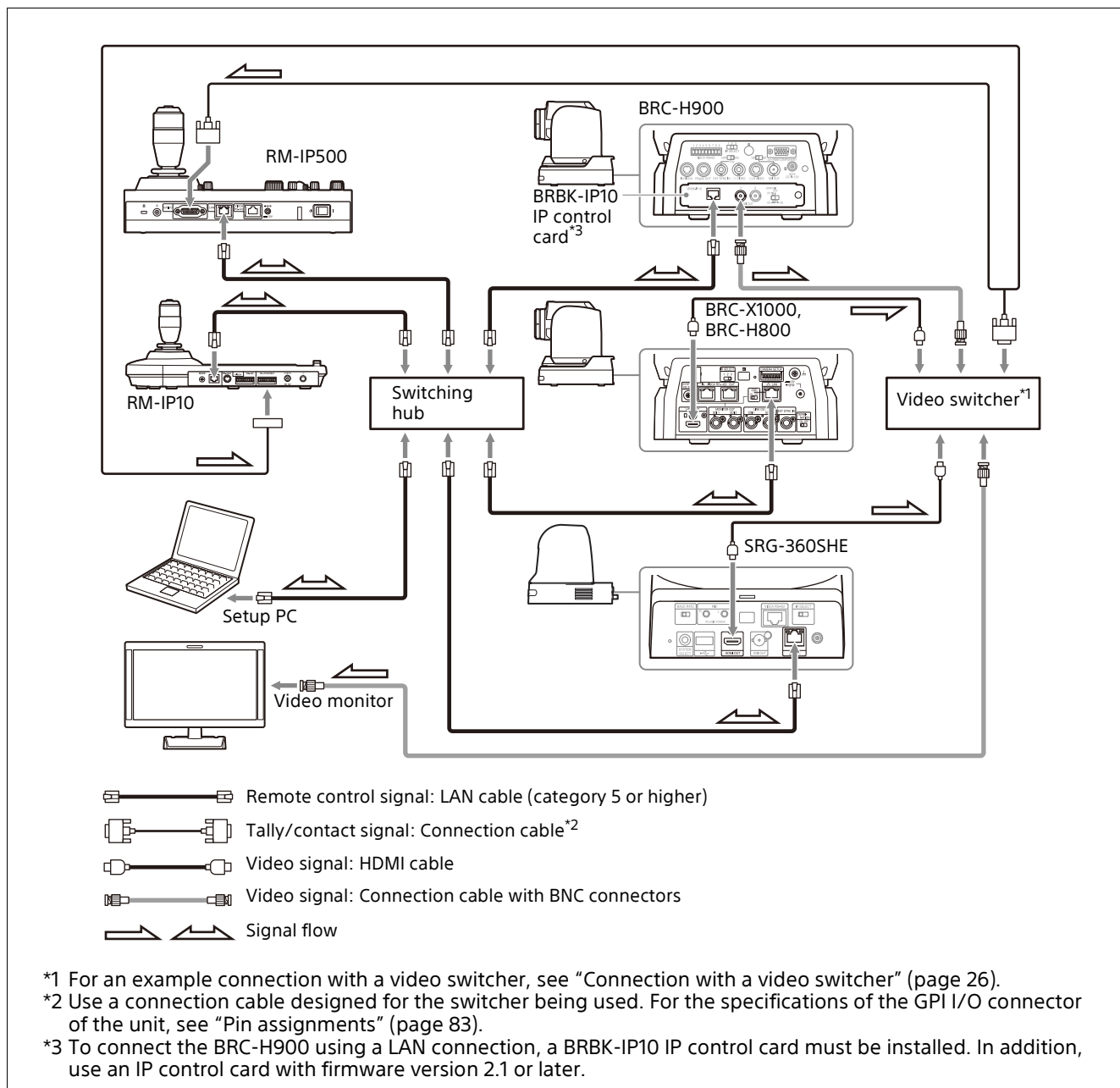

1 Connect the LAN connector of the units and LAN connector of the cameras using LAN cables.
 You can connect up to 100 cameras and five remote controllers on the same network.

2 To configure setting of the unit and cameras using setup software, connect a PC to the same network.

- Use shielded-type LAN cables to prevent malfunction that may result from radiation noise.
- Use a LAN cable (category 5 or higher).
- Connect the cameras, remote controllers, and PC via switching hubs (10BASE-T or 100BASE-TX). Use on a network with significant packet loss or delay may cause a malfunction. Use a high-quality network.
- Do not mix 10BASE-T and 100BASE-TX in the network.

- The IP address of the unit is set to 192.168.0.10, and the IP address of a camera and BRBK-IP10 IP control card is set to 192.168.0.100 by factory default. For an ILME-FR7 target camera, the IP address is automatically assigned using DHCP by factory default.
- Connecting stackable switching hubs in up to 2-tier configuration is recommended to avoid network delay.

Notes

- Do not connect more than 100 cameras, five remote controllers, and one setup PC across all networks, even if controlling a camera that is on a network of a different segment via a router. If you connect more devices than this, problems may occur, such as control delays or cameras are operated incorrectly due to IP address duplication.
- If you perform the setup from multiple PCs, the settings may not be made correctly. Perform the setup from one PC.
- Set the setup PC so that only the network that you use is enabled.
- Do not connect cameras and remote controllers to a public network.

3 Connect the cameras and remote controllers to AC outlets using AC adapters and AC power cords.

Assigning cameras

Link the camera numbers, used for operating cameras from the unit, with the cameras on the network. This is called camera assignment. A list of the assigned cameras is saved in the unit as a camera table.

Camera numbers are sequential in each group, and are selected using the GROUP buttons and CAMERA number buttons of the camera selection block.

Camera assignments are performed using AUTO IP SETUP > SETUP IP or AUTO IP SETUP > ASSIGN CAM in the RM menu.

Notes

- Only cameras that are on the same segment as the remote controller can be assigned using AUTO IP SETUP. Use the setup software to assign cameras on different segments.
- For an ILME-FR7, run AUTO IP SETUP within 20 minutes of starting the camera.

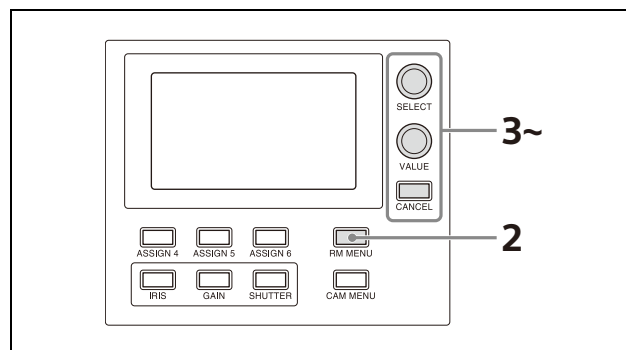

- 1 Check that the assigned camera is connected to the network, and that the camera power is turned on.**
- 2 Press the RM MENU button, turning it on (button is lit yellow).**
The RM menu top menu appears.
- 3 Turn the SELECT knob to move the cursor to AUTO IP SETUP.**
- 4 Press the SELECT button.**
The AUTO IP SETUP menu appears.
- 5 Turn the SELECT knob to select SETUP IP or ASSIGN CAM, and press the SELECT button.**
Select one of the following methods, depending on the type of camera assignment.
 - For connections on a new network: "Assignment using AUTO IP SETUP > SETUP IP" (page 18)
 - For adding an assignment to an existing network: "Assignment using AUTO IP SETUP > ASSIGN CAM" (page 19)

Assignment using AUTO IP SETUP > SETUP IP

This method detects cameras on the network, and automatically assigns the IP address setting and camera number for unregistered cameras.

Use this method when constructing a new network.

With this method, you specify the range of IP addresses assigned to cameras by entering the start address in [FROM] and the end address in [TO].

Set the range of IP addresses for assignment so that they are in the same segment as the remote controller.

Note

The same IP address as a remote controller cannot be set.
The subnet mask (SM) and gateway address (GW) of the camera are assigned the same settings as the remote controller.
The DHCP setting of the camera is set to Off.

```
<SETUP IP>
[FROM]
IP: →192. 168. 0. 100
[TO]
IP: 192. 168. 0. 199
SETUP IP : NOT EXEC

PRST:TRACE
```

- ① **Turn the SELECT knob to move the cursor to IP under [FROM].**
- ② **Set the start value of the IP addresses to assign to newly registered cameras.**
Turn the SELECT knob clockwise to move the cursor to the first three digits (for example, 192).
IP: →192. 168. 0. 100
- ③ **Turn the VALUE knob to set the value.**
Turning clockwise increases the value, and turning counterclockwise decreases the value.
- ④ **Turn the SELECT knob to move to the next number and repeat step ③ to set the other numbers.**
- ⑤ **Turn the SELECT knob to move the cursor to IP under [TO].**
- ⑥ **Set the end value of the IP addresses to assign to newly registered cameras.**
Turn the SELECT knob clockwise to move the cursor to the first three digits (for example, 192).
IP:→192. 168. 0. 199
- ⑦ **Turn the VALUE knob to set the value.**
Turning clockwise increases the value, and turning counterclockwise decreases the value.
- ⑧ **Turn the SELECT knob to move to the next number and repeat step ⑦ to set the other numbers.**
- ⑨ **When finished making all settings, turn the SELECT knob to move the cursor to SETUP IP.**
- ⑩ **Turn the VALUE knob to change NOT EXEC to EXEC, then press the VALUE button.**
A "WAIT FOR A FEW SECONDS" message is displayed on the screen.

- ⑪ **When the message disappears, turn the VALUE knob to change NO to YES, then press the VALUE button.**

```
<CONFIRM EXECUTION>
→CONFIRM : YES
```

- ⑫ **Check the camera assignment result using AUTO IP SETUP >CAMERA TABLE in the RM menu.**
For details about displaying CAMERA TABLE, see "To check the camera table" (page 21).

Assignment using AUTO IP SETUP >ASSIGN CAM

This method is used to assign camera numbers to cameras that already have a configured IP address.
With this method, you can specify the group number and camera number of the camera selection button from which to start assignments.
Camera assignments are made in ascending IP address order.
For details about the group number and camera number, see "Selecting a Camera" (page 34).

Note

Only cameras within the same segment can be assigned.

```
<ASSIGN CAM>
[FROM]
→GROUP NUM : 01
CAMERA NUM : 01
KEEP IP : NOT EXEC

PRST:TRACE
```

- ① **Turn the SELECT knob to move the cursor to GROUP NUM.**
Set the group number for which to begin assignment.
- ② **Turn the VALUE knob to set the value.**
Turning clockwise increases the value, and turning counterclockwise decreases the value.
- ③ **Turn the SELECT knob to move the cursor to CAMERA NUM.**
Set the camera number for which to begin assignment.

- ④ Turn the **VALUE** knob to set the value. Turning clockwise increases the value, and turning counterclockwise decreases the value.
- ⑤ When finished making all settings, turn the **SELECT** knob to move the cursor to **KEEP IP**.
- ⑥ Turn the **VALUE** knob to change **NOT EXEC** to **EXEC**, then press the **VALUE** button. A "WAIT FOR A FEW SECONDS" message is displayed on the screen.
- ⑦ When the message disappears, turn the **VALUE** knob to change **NO** to **YES**, then press the **VALUE** button.

```
<CONFIRM EXECUTION>
→CONFIRM      : YES
```

To add cameras

Perform the configuration again using **AUTO IP SETUP >SETUP IP** or **AUTO IP SETUP >ASSIGN CAM**. Assigned cameras are added to the bottom of the camera table.

For details, see "Assignment using **AUTO IP SETUP >SETUP IP**" (page 18) or "Assignment using **AUTO IP SETUP >ASSIGN CAM**" (page 19).

To clear the camera table

You can clear all the camera information stored in the camera table.

Note

The camera table cannot be restored once it has been cleared.

- 1 Press the **RM MENU** button, turning it on (button is lit yellow). The RM menu top menu appears.
- 2 Turn the **SELECT** knob to move the cursor to **AUTO IP SETUP**.
- 3 Press the **SELECT** button. The **AUTO IP SETUP** menu appears.
- 4 Turn the **SELECT** knob to select **CLEAR TABLE**, and press the **SELECT** button. The **CLEAR TABLE** menu appears.
- 5 Turn the **VALUE** knob to change **NOT EXEC** to **EXEC**, then press the **VALUE** button.

- 6 Turn the **VALUE** knob to change **NO** to **YES**, then press the **VALUE** button.

```
<CONFIRM EXECUTION>
→CONFIRM      : YES
```

To swap camera numbers

You can change the camera numbers after IP addresses have been configured automatically.

- 1 Press the **RM MENU** button, turning it on (button is lit yellow). The RM menu top menu appears.
- 2 Turn the **SELECT** knob to move the cursor to **AUTO IP SETUP**.
- 3 Press the **SELECT** button. The **AUTO IP SETUP** menu appears.
- 4 Turn the **SELECT** knob to select **SWAP CAM**, and press the **SELECT** button. The **SWAP CAM** menu appears.

```
<SWAP CAM>
→CAMERA A    : 01-01
  IP:         : 192.168. 0.100
  MAC:        : xx-xx-xx-xx-xx-xx
CAMERA B     : 01-02
  IP:         : 192.168. 0.110
  MAC:        : xx-xx-xx-xx-xx-xx
SWAP A<=>B   : NOT EXEC
PRST:TRACE
```

This screen is used to swap the camera information of **CAMERA A** and **CAMERA B**.

- 5 Turn the **SELECT** knob to move the cursor to **CAMERA A**.
- 6 Turn the **VALUE** knob to change the camera group number and the camera number of the camera to swap.

```
→CAMERA A    : 01-01
                | |
                | | Camera number
                | |
                | | Group number
```

The IP address and MAC address of the corresponding camera are displayed in **IP** and **MAC**, respectively.

- 7 Turn the **SELECT** knob to move the cursor to **CAMERA B**.

- 8 Enter the camera group number and the camera number of the camera to swap using the same procedure for CAMERA A.
- 9 Turn the SELECT knob to move the cursor to SWAP A<=>B.
→SWAP A<=>B : NOT EXEC
- 10 Turn the VALUE knob to change NOT EXEC to EXEC, then press the VALUE button.
- 11 Turn the VALUE knob to change NO to YES, then press the VALUE button.

```
<CONFIRM EXECUTION>
→CONFIRM      : YES
```

- 12 Check the result using AUTO IP SETUP >CAMERA TABLE in the RM menu.

Changing the camera registration and settings manually

You can change the group number, camera number, and IP address assigned to a camera or clear the camera registration manually using AUTO IP SETUP >MANUAL.

- 1 Press the RM MENU button, turning it on (button is lit yellow).
The RM menu top menu appears.
- 2 Turn the SELECT knob to move the cursor to AUTO IP SETUP, and press the SELECT button.
The AUTO IP SETUP menu appears.
- 3 Turn the SELECT knob to select MANUAL, and press the SELECT button.
The MANUAL menu appears.

```
<MANUAL>
 [CURRENT]
→CAMERA      : 01-02
 IP: 192. 168.   0.  50
 [CHANGE]
 CAMERA      : 01-02
 IP: 192. 168.   0.  50
 MANUAL SET  : NOT EXEC
 PRST:TRACE
```

- 4 Turn the SELECT knob to move the cursor to CAMERA under [CURRENT].
- 5 Turn the VALUE knob to select the camera group number and the camera number of the camera to change.

To change the registration

- ① Turn the SELECT knob to move the cursor to CAMERA under [CHANGE].
- ② Turn the VALUE knob to select the camera group number and the camera number of the camera assignment to change to.

To clear the registration

- ① Turn the SELECT knob to move the cursor to [CHANGE].
- ② Turn the VALUE knob to change [CHANGE] to [CLEAR].

- 6 Turn the SELECT knob to move the cursor to MANUAL SET.

- 7 Turn the VALUE knob to change NOT EXEC to EXEC, then press the VALUE button.
When changing the registration, a "WAIT FOR A FEW SECONDS" message is displayed on the screen.

- 8 Turn the VALUE knob to change NO to YES, then press the VALUE button.

```
<CONFIRM EXECUTION>
→CONFIRM      : YES
```

- 9 Check the result using AUTO IP SETUP >CAMERA TABLE in the RM menu.

To check the camera table

You can check all the camera information in the camera table.

- 1 Press the RM MENU button, turning it on (button is lit yellow).
The RM menu top menu appears.
- 2 Turn the SELECT knob to move the cursor to AUTO IP SETUP.
- 3 Press the SELECT button.
The AUTO IP SETUP menu appears.
- 4 Turn the SELECT knob to select CAMERA TABLE, and press the SELECT button.
The CAMERA TABLE menu appears.
The camera information for cameras 1 to 5 in group 1 are displayed on the screen.

VISCA RS-422 (serial) connection

You can connect multiple cameras in a serial connection using the VISCA RS-422 OUT connectors. In a serial connection, a remote controller can control up to seven cameras. These cables support connection at distances of up to 1.2 km.

Use a LAN straight cable for RS-422 connection using the RJ-45 connector.

Connecting remote controllers and cameras using serial connection

Connection example

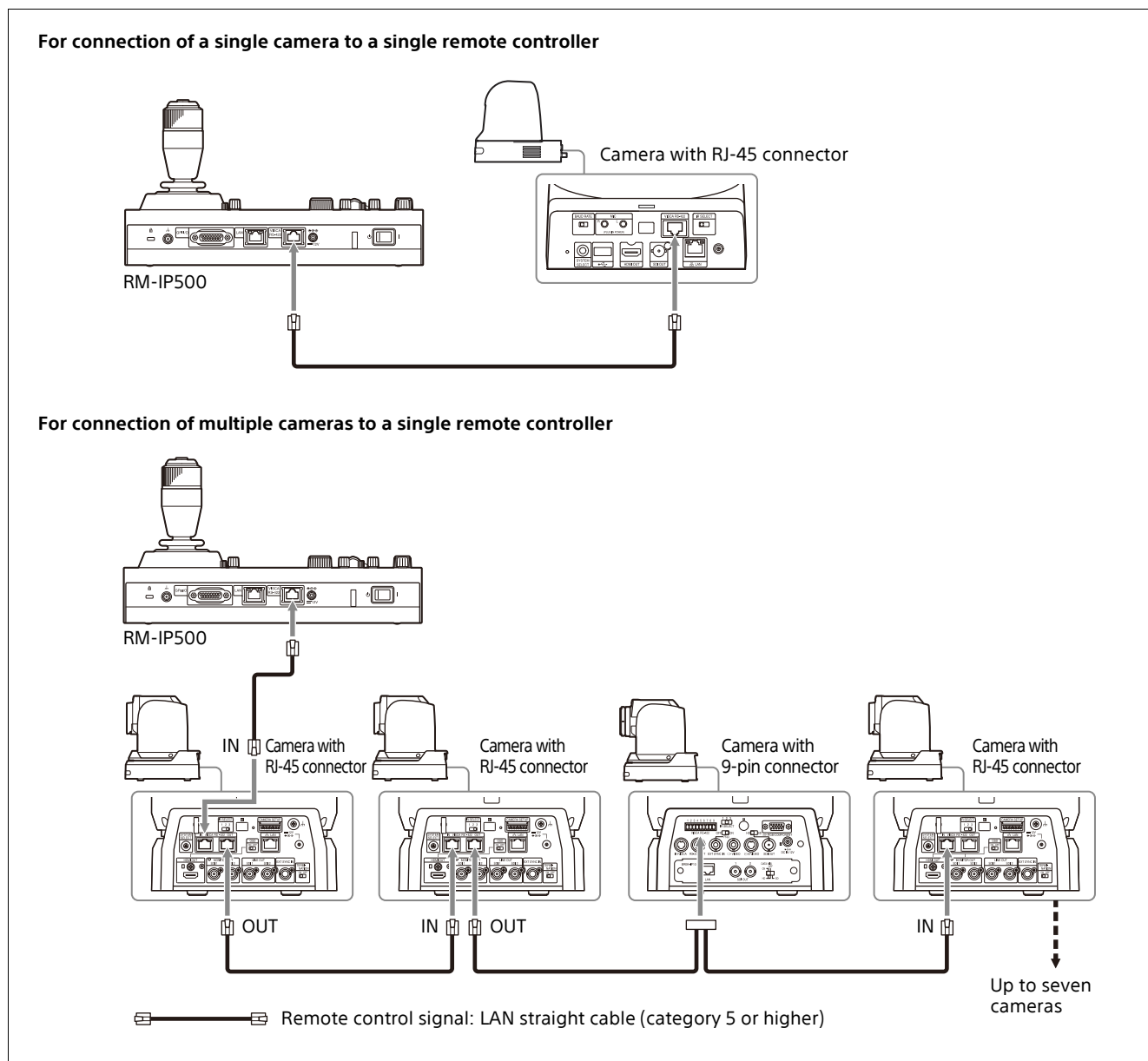

Notes

- When connecting an SRG-360SHE in a serial connection, only one SRG-360SHE camera can be connected to a single remote controller. To connect multiple SRG-360SHE cameras or to mix with other model cameras, use the connection described in "VISCA over IP (LAN) connection" (page 15).
- The ILME-FR7 does not support serial connection.

VISCA RS-422 connection diagram example

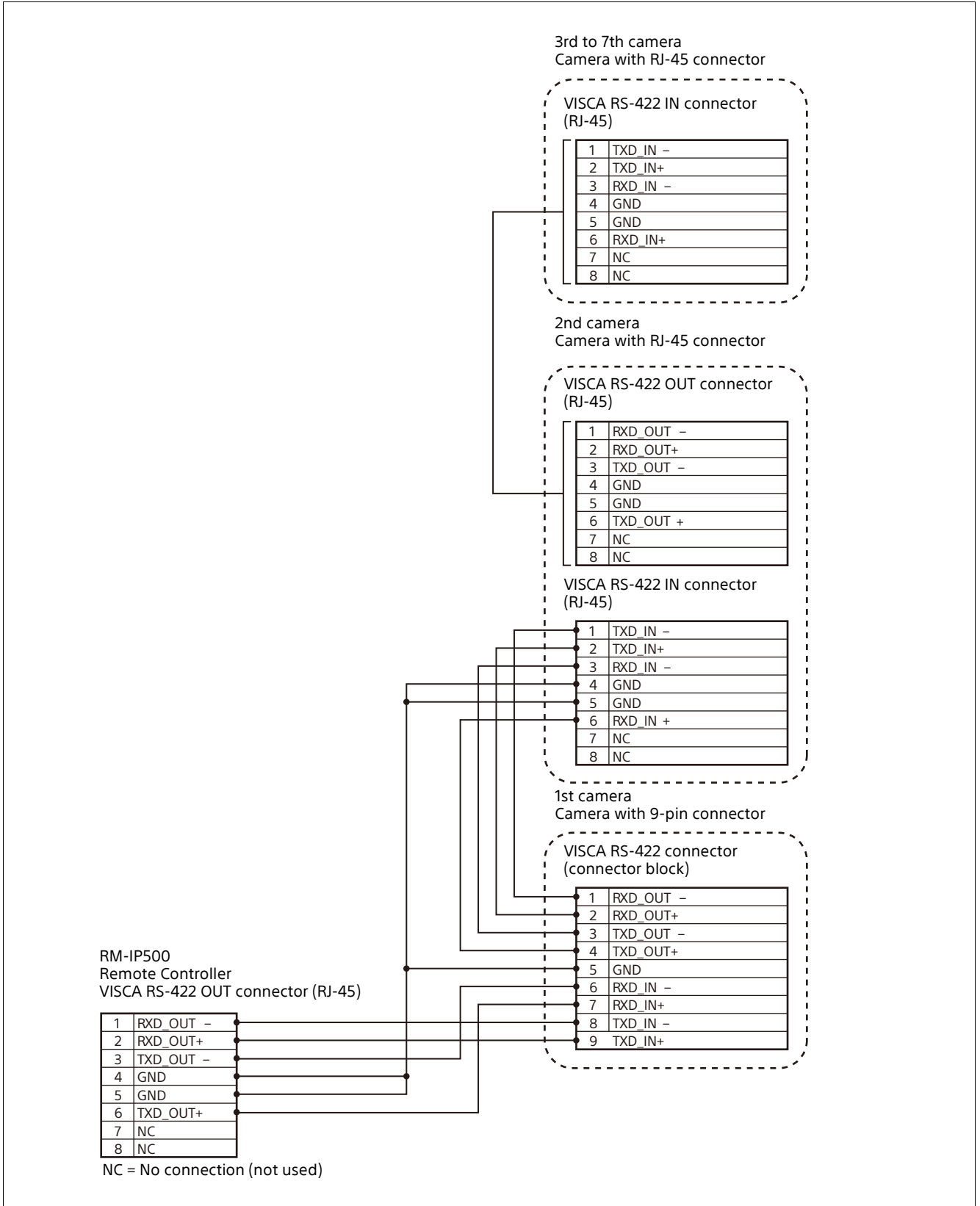

Configuring a serial connection

After cameras are connected correctly, select serial connection using CONFIG >SERIAL in the RM menu, set the baud rate, and assign camera addresses.

Note

If a connected camera is changed after completing the configuration, the cameras must be configured again.

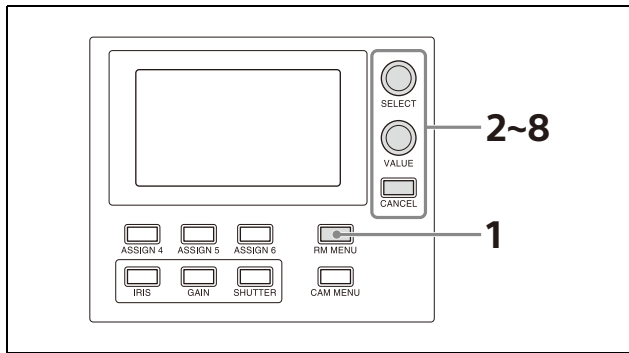

- 1 Press the RM MENU button, turning it on (button is lit yellow).**
The RM menu top menu appears.
- 2 Turn the SELECT knob to move the cursor to CONFIG.**
- 3 Press the SELECT button.**
The CONFIG menu appears.
- 4 Turn the SELECT knob to move the cursor to SERIAL, and press the SELECT button.**
The SERIAL menu appears.

Set the baud rate, as required.
Turn the SELECT knob to move the cursor to BAUD RATE, turn the VALUE knob, and select 9600 or 38400.
The default setting is 9600.

- 5 Turn the SELECT knob to move the cursor to APPLY.**

```

<SERIAL>
  BAUD RATE   : 9600
  →APPLY      : NOT EXEC

PRST:TRACE
  
```

- 6 Turn the VALUE knob to change NOT EXEC to EXEC, then press the VALUE button.**
The following message appears after changing the connection method from LAN connection to serial connection or changing the baud rate, prompting you to reboot the unit.

```

<CONFIRM EXECUTION>
→CONFIRM      : NO

REBOOT SYSTEM
  AFTER CONFIRMATION

PRST:TRACE
  
```

- 7 Turn the VALUE knob to change NO to YES, then press the VALUE button.**
The unit reboots automatically.

Upon rebooting, the serial connection setting is completed.

Connection with a video switcher

By connecting the tally output of a video switcher to the GPI I/O connector of the unit, the tally input lamps of the unit light up in unison with the switcher operation which you can use to switch the target camera to control.

The following diagram shows the connection with an MCX-500 Multi-Camera Live Producer as an example.

Connection example

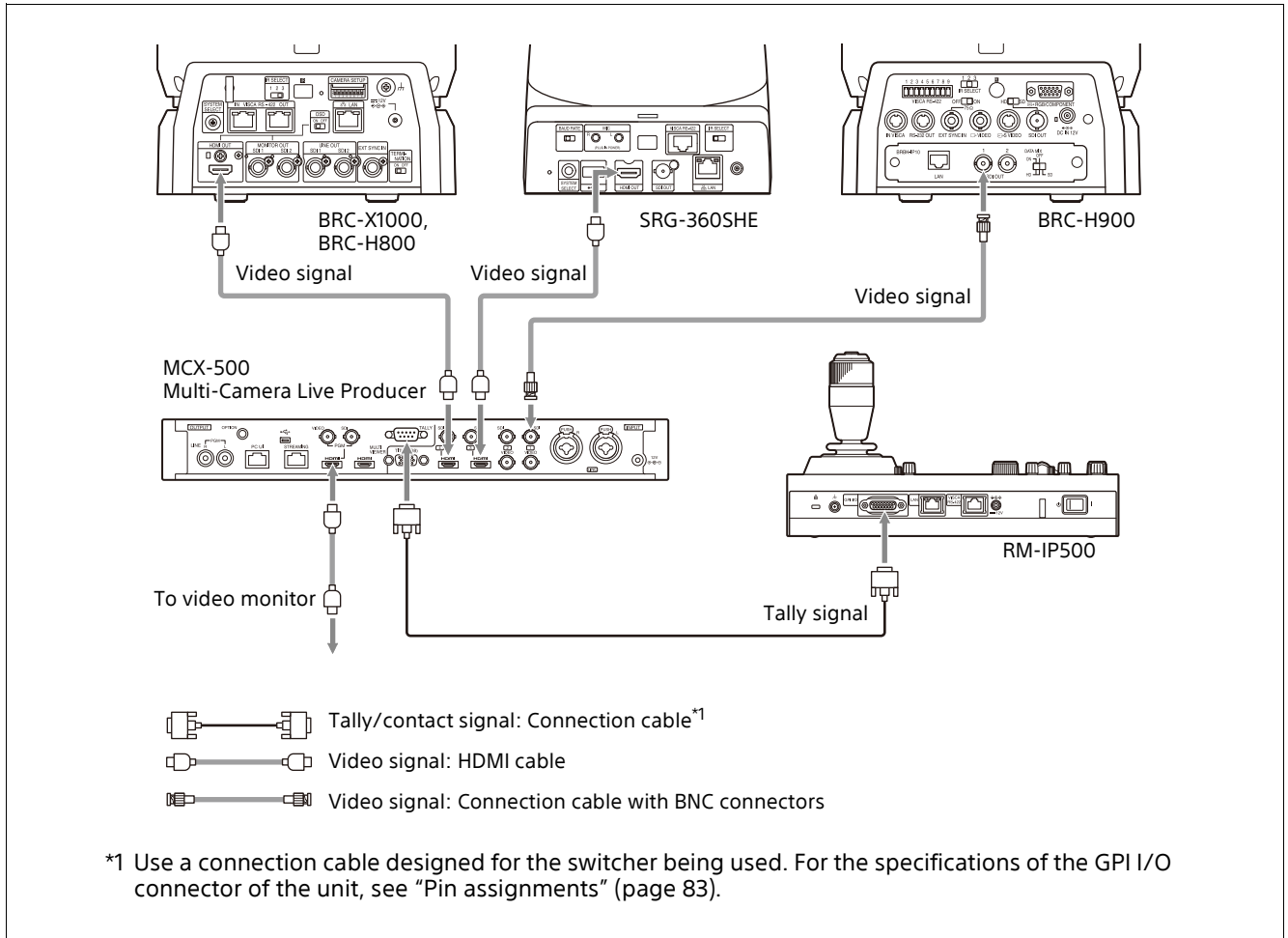

Connection with ILME-FR7

The following diagram shows a connection example for operating an ILME-FR7.

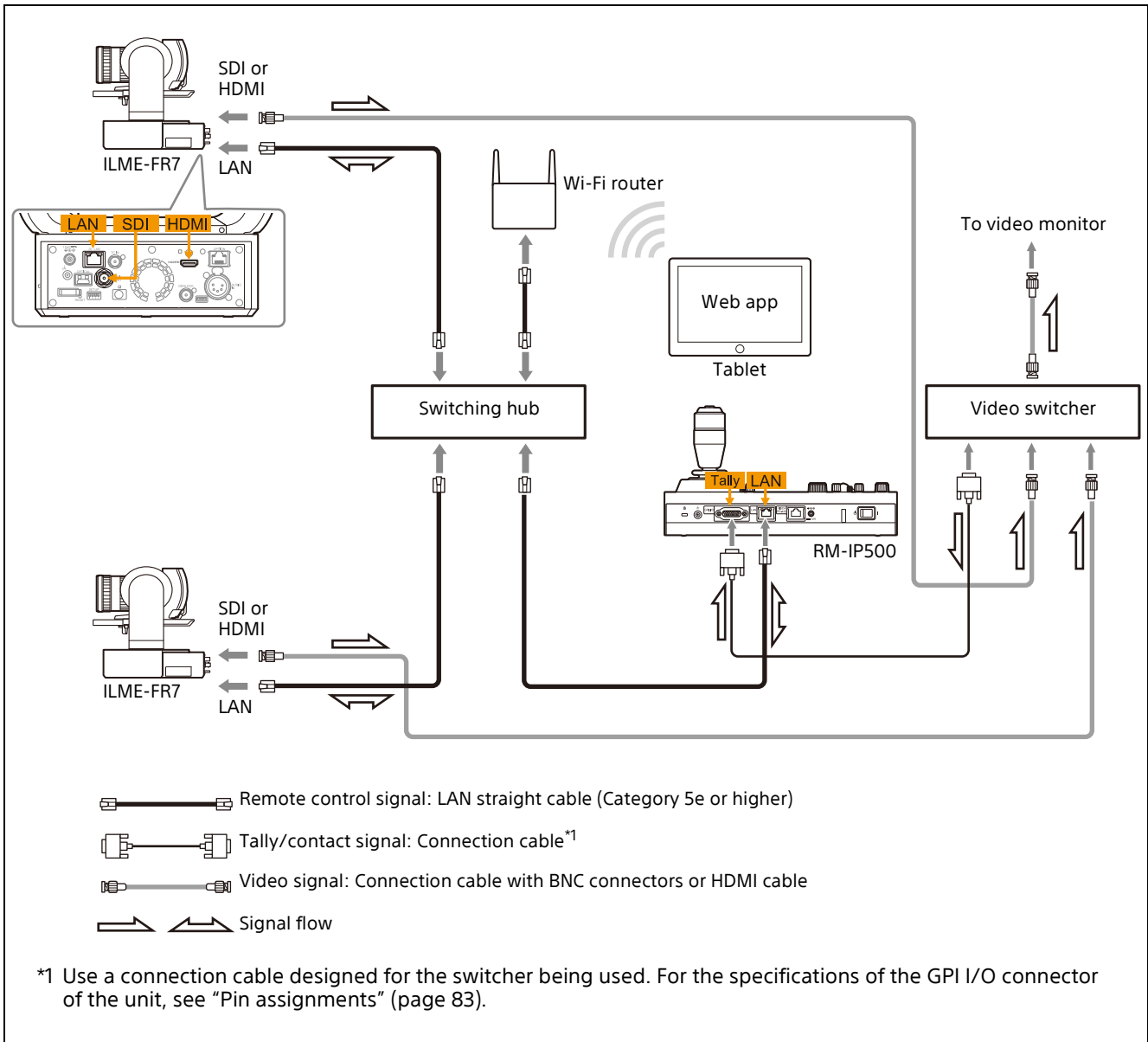

Using a Setup PC

When the unit is connected with cameras by LAN connection, you can save the settings saved on the unit to a setup PC by connecting the PC to the network.

The configuration data saved on the PC can be used to recover settings if a failure occurs or can be used to configure another remote controller. You can also update the firmware of the unit.

Saved configuration data

- CONFIG MENU settings of the unit
- Camera table
- Control panel status

For details about connecting the setup PC to a network, see "Connecting remote controllers, cameras, and setup PC using LAN connection" (page 17).

System requirements for the setup PC

The following operating environment is required for the PC on which to install the setup software.

- CPU: Intel Core2 Duo 2.4 GHz or higher (recommended)
- Memory: 1 GB or more (recommended)
- Hard disk: More than 50 MB free space
- OS: Windows 10, Windows 11
- Web browser: Microsoft Edge, Google Chrome

Accessing a remote controller

To access the unit from the setup PC, perform the following procedure beforehand using the RM menu.

- 1 Press the RM MENU button, turning it on (button is lit yellow).**
The RM menu top menu appears.
- 2 Turn the SELECT knob to move the cursor to MAINTENANCE.**
- 3 Press the SELECT button.**
The MAINTENANCE menu appears.
- 4 Turn the SELECT knob to move the cursor to UPDATE MODE.**
- 5 Press the SELECT button.**
The UPDATE MODE setup screen appears.

- 6 Turn the VALUE knob to change OFF to ON, then press the VALUE button.**

The buttons and LED indicators start blinking, and a one-time password for accessing the unit from a web browser is displayed on the LCD panel.

```
<UPDATE MODE>
→UPDATE MODE : ON

      PASSWORD :XXXXXXXXX

PRST : TRACE
```

Notes

- The one-time password will become invalid if the unit is rebooted or UPDATE MODE is set to OFF. In this case, acquire another one-time password.
- To return to normal operating mode after setting UPDATE MODE to ON, set UPDATE MODE to OFF and then press the VALUE button.

- 7 Access the URL of the target IP controller using a web browser on the PC.**
To save configuration data on a PC (backup) or restore:

```
http://<IP address of unit>:52382/
backup/
```

To update the firmware:

```
http://<IP address of unit>:52382/
versionup/
```

The Windows authentication dialog appears.

- 8 Enter the user name and password in the Windows authentication dialog.**
 - User name: RM_IP_USER
 - Password: One-time password obtained by the UPDATE MODE setting.
- 9 Click the OK button.**
The [Backup/Restore] screen or [Firmware Update] screen appears.

Saving configuration data on a PC (Backup)

- 1 Access the URL of the remote controller whose configuration data you want to save using a web browser on the PC.**
http://<IP address of unit>:52382/backup/
- 2 Access the save target remote controller.**
For details about the access method, see "Accessing a remote controller" (page 28).

The [Backup/Restore] screen appears.
- 3 Click the [Backup] button.**
The configuration data backup starts.
The default file name of the configuration data file is rm-ip500.cfg.

Restoring using configuration data

You can restore the unit or another RM-IP500 using controller configuration setup data saved on a PC.

- 1 Access the remote controller you want to restore using a web browser on the PC.**
For details about the access method, see "Accessing a remote controller" (page 28).

The [Backup/Restore] screen appears.
- 2 Click the [Browse] button.**
The file selection dialog appears.
- 3 Select the saved controller configuration data.**
- 4 Click the [Restore] button on the [Backup/Restore] screen.**
The restore process starts.

When the configuration data is restored, the following message appears and then the remote controller reboots.

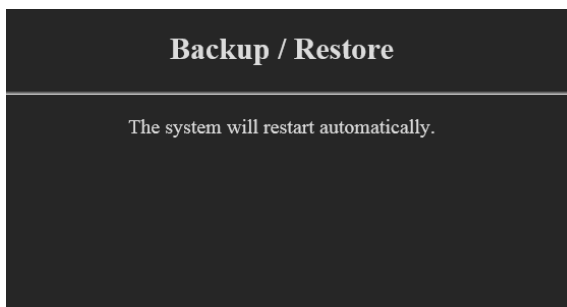

Updating the firmware

- 1 Download the firmware update from the download site.**
- 2 Uncompress the downloaded compressed file.**
- 3 Access the remote controller you want to update using a web browser on the PC.**
For details about the access method, see "Accessing a remote controller" (page 28).

The [Firmware Update] screen appears.

- 4 Click [Yes].**



The start screen appears.

- 5 Click the [Start] button.**

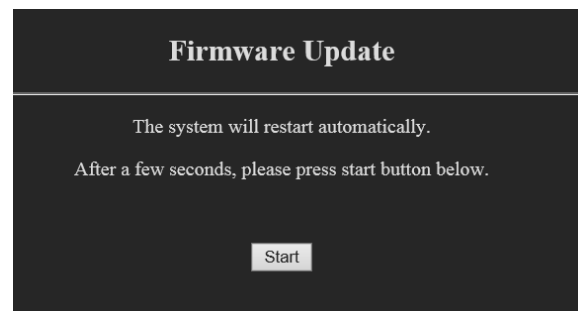

The firmware selection screen appears.

- 6 Click the [Browse] button, and select the firmware update.**
- 7 Click the [OK] button.**
The version update starts.
During the version update, "UPDATING" is displayed on the LCD panel of the unit. When the version update is finished, an update completion message appears and the unit reboots automatically.
- 8 Press the RM MENU button to display the RM menu.**

9 Check the version using MAINTENANCE >MODEL INFO.

About the RM-IP Setup Tool

This is a software tool for configuring remote controller settings. It is used to configure the following.

- IP address settings
- Camera assignments
- Swapping camera numbers
- Checking camera tables

Install the software on the setup PC for the unit. The setup tool software and setup tool guide can be downloaded from the download site. For details, refer to the RM-IP Setup Tool guide.

Note

To use the RM-IP Setup Tool, set MAINTENANCE >UPDATE MODE to ON in the RM menu.

Using the Panel Sheet for ILME-FR7

When using an ILME-FR7 with this unit, greater efficiency can be achieved by using the supplied panel sheet for ILME-FR7 with the function names printed on it that correspond to the button/knob names when the target camera is an ILME-FR7.

The following diagram shows the panel sheet attached to the unit. The buttons and knobs shown in the thick frames are marked with the function name for an ILME-FR7.

Note

If you already use this unit, you can purchase the panel sheet separately. For details, consult with your Sony dealer.

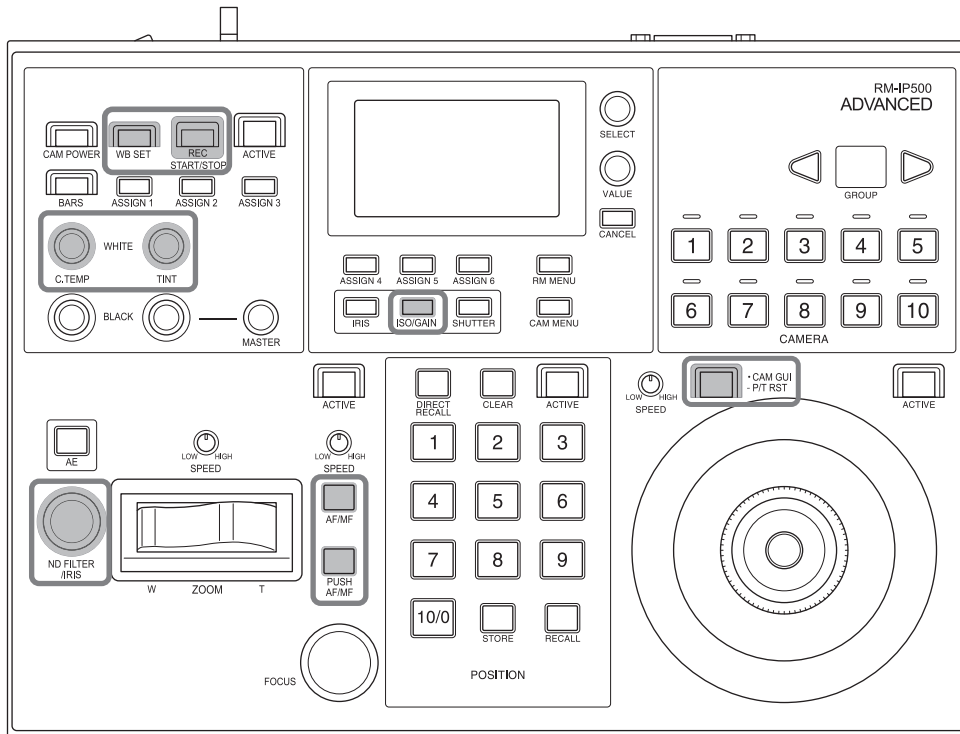

To use the panel sheet adhesively attached to the panel surface, attach the panel sheet using the following procedure.

- 1 Remove any dirt from the panel surface.** Clean the surface using a cloth moistened with a diluted neutral detergent.

Note

Do not use alcohol or solvent to clean the panel surface as it may damage the panel surface.

2 Remove the backing paper from the double-sided adhesive tape on the rear side.

There are three backing paper pieces.

Note

Do not touch the adhesive surface.

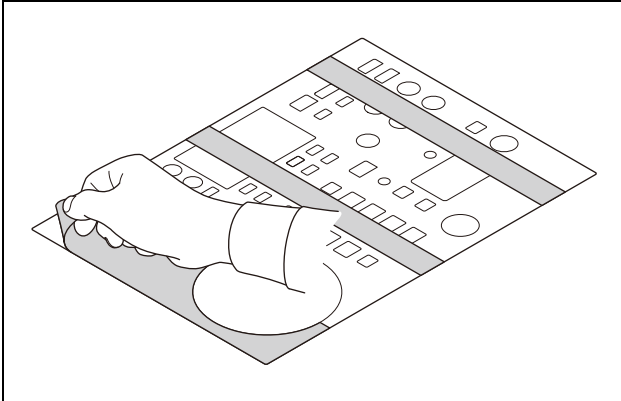

3 Attach the panel sheet to the panel surface using the dotted lines in the following diagram as a guide.

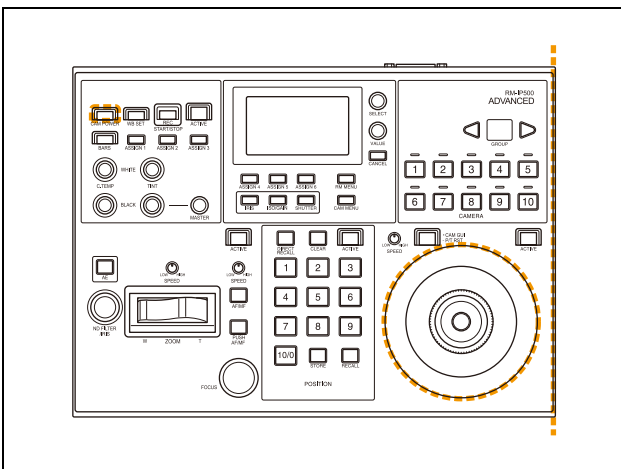

4 Press down on the adhesive areas to secure the panel sheet.

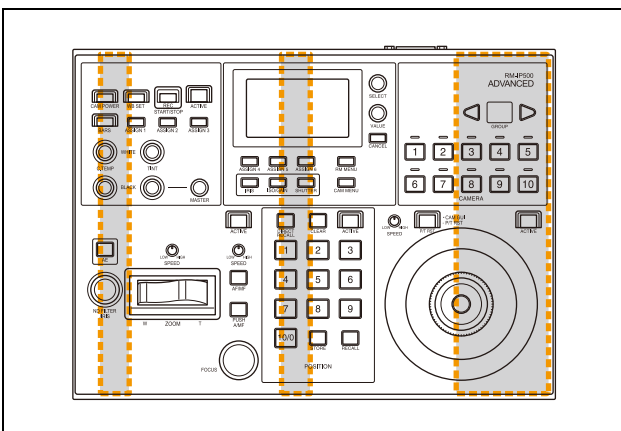

Operations

Before operation, make sure that cameras, the unit, and peripheral devices are installed and connected correctly.

Turning on the Power

- 1 Turn on the camera(s).
- 2 Set the power switch on the rear of the unit to the I (on) position.

Note

When the unit is mounted in a control console, turn the power on/off using the main power supply of the console.

When the unit is first turned on, all the buttons on the operation panel light up and then turn off.

Next, the buttons that were selected when the unit was last turned off light up. The CAMERA 1 button is lit yellow the first time the unit is turned on.

When using a LAN connection, the camera group number that was selected when the unit was last turned off is displayed in the group number display.

- 3 Turn on the peripheral devices.

Notes

- Be sure to turn on the power of the cameras before the power of this unit.
- Do not touch the joystick or ZOOM lever when turning on the power of the unit. Touching the joystick or ZOOM lever will prevent the center point position check from operating correctly when power is applied.

To turn the unit off

To turn the unit off to change connection or perform maintenance, use the reverse procedure of turning the unit on.

To turn the cameras on/off (standby) using the unit

If power is supplied to a camera, you can turn the camera on/off (standby) using the CAM POWER button of the color adjustment block.

- Select the camera that you want to turn on/off (standby), and press the CAM POWER button. When the camera turns on, the CAM POWER button lights up. When the camera is off (standby), the button is not lit.
- You can turn all cameras registered in the camera table on/off (standby) at the same time by setting CONFIG >CAM POWER to ALL in the RM menu and pressing the CAM POWER button.

Selecting a Camera

Assign camera numbers to the cameras, and then select a camera number on the camera selection block when you want to control the corresponding camera.

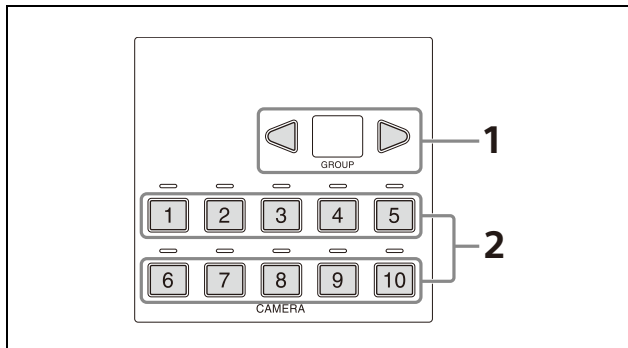

The number of camera numbers that can be assigned to cameras to control varies depending on the use of LAN connection or serial connection. The method of selecting the camera number also is different.

Selecting a camera when using LAN connection

For LAN connection, ten camera numbers are assignable in camera groups 1 to 10, supporting assignment of up to 100 cameras.

- 1 Select the camera group to which the target camera belongs using the GROUP LEFT button and GROUP RIGHT button.**
You can select from group 1 to 10.
The number of the selected group is displayed in the group number display.
After switching the group number, the CAMERA 1 button is selected in the group.
- 2 Press the number of the CAMERA button to select.**
The selected button lights in yellow.

Selecting a camera when using serial connection

You can select a camera number using the CAMERA 1 to CAMERA 7 buttons.
The pressed CAMERA button lights in yellow, and the camera assigned with the same camera number as the CAMERA button becomes the target camera.

For serial connection, camera numbers up to number 7 can be assigned.
In a serial connection, groups are not used, hence the group buttons do not light up.

About the color of camera buttons

The camera number button for the selected camera is lit yellow.
When a camera is turned on or is in standby mode, the camera number buttons for cameras that can be operated are lit blue.

About the tally input lamp indicators

When the GPI I/O connector of the unit is configured as an input, you can connect the tally output of an external device to the unit to display tally input lamps (ON AIR TALLY mode), or switch the target camera in response to the operation of the external device (NORMAL TALLY mode).

- 1 Set CONFIG >GPI I/O >SETTING to INPUT in the RM menu.**
- 2 Set CONFIG >GPI I/O >TALLY MODE in the RM menu.**
When set to NORMAL, normal tally mode is selected. The target camera of the unit is switched in response to the tally output of the external device, and the corresponding tally input lamp lights up.

You can also display the tally lamp on the corresponding camera.
For details, see "TALLY MODE" (page 75).

Note

If the tally input changes while NORMAL is selected, the target camera will change as follows.

Tally input change	Target camera
No tally input	The CAMERA 1 to CAMERA 10 buttons for all target cameras can be selected.
Change from no tally input to tally input received	The camera corresponding to the tally input number automatically becomes the target camera. If multiple numbers are input, the camera with the lowest number becomes the target camera.
Tally input continues	If there is only one tally input number, the target camera cannot be changed. If there are multiple tally input numbers, you can select one of them to become the target camera.
Change from tally input to no tally input	The current target camera does not change.

- When set to ON AIR, on-air tally mode is selected. The tally output of the camera selected by the external device is displayed by the corresponding tally input lamp of the unit. Note that the target camera cannot be switched in conjunction with the tally input, but must be switched using the camera buttons on the unit. The tally lamp on the corresponding camera can also be set to light up in response to the tally input. For details, see "CAMERA LINK" (page 75).

When the GPI I/O connector is used as a contact output connector, the number of the target camera is sent to the connected external device. When CONFIG >GPI I/O >SETTING is set to OUTPUT in the RM menu, the camera number of the selected camera is output to the external device.

You can also display the tally lamp on the camera selected on the unit. For details, see "CAMERA LINK" (page 75).

Operating a Camera

Pan and tilt control

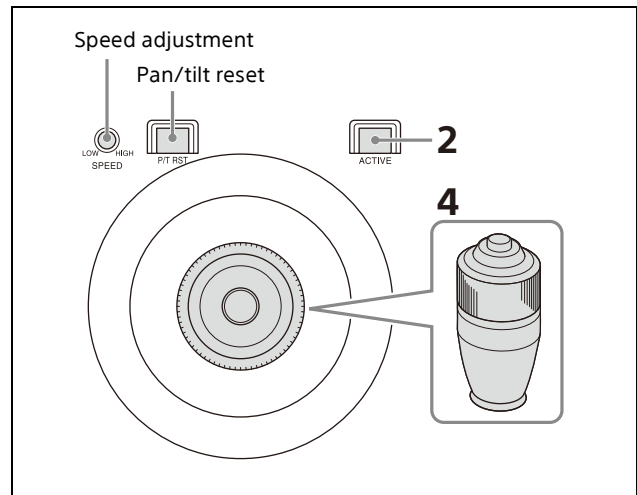

- 1 Select the target camera to control.**
For details about selection, see "Selecting a Camera" (page 34).
- 2 Press the ACTIVE button, turning it on (button is lit), on the joystick control block.**
- 3 For an ILME-FR7 target camera, check that the CAM GUI / P/T RST button is not lit.**
If it is lit, press the button to turn it off.
- 4 Operate the joystick to pan or tilt the camera.**
While checking the picture on the screen, incline the joystick in the desired direction. The panning/tilting speed changes according to the angle at which you incline the joystick.
Return the joystick to the center position to stop pan/tilt operation.

To adjust the pan/tilt speed

You can adjust the pan/tilt speed, obtained when you incline the joystick at the maximum angle, and the change in speed in response to the angle of inclination.

Turning the PAN-TILT SPEED knob clockwise increases the speed, and turning counterclockwise decreases the speed.

To face the camera toward the front (move to home position)

Press and hold the button on the joystick.

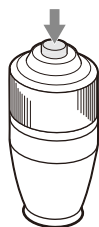

If you accidentally move the camera head with your hand

If you move the camera head with your hand, or your hand or other object in the vicinity of the camera bumps the camera during pan/tilt movement, the camera pan/tilt movement may be incorrect. If this occurs, the STANDBY lamp (POWER lamp on the ILME-FR7) and NETWORK lamp of the camera blink to indicate incorrect operation.

In this case, press and hold the CAM GUI / P/T RST (pan/tilt reset) button to reset the pan/tilt position.

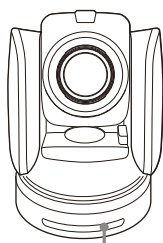

STANDBY lamp blinks.

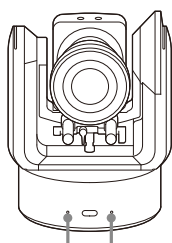



POWER lamp blinks.

NETWORK lamp blinks.

If the camera moves in a different direction than the joystick

By default, the camera pans to the right whenever the joystick is inclined to the right. If you want the camera to face toward the opposite direction, for example, when changing the direction of the camera while checking the picture on a screen, you can change the direction the camera moves using CONFIG >DIRECTION in the RM menu.

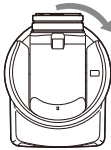
For details about configuration, see "DIRECTION" (page 74).

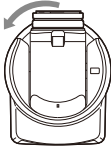
Joystick	Movement of the camera	CONFIG >DIRECTION setting
Incline to the right 		Pan operation: Set JOYSTICK PAN to STANDARD. Tilt operation: Set JOYSTICK TILT to STANDARD.
Incline to the right 		Pan operation: Set JOYSTICK PAN to REVERSE. Tilt operation: Set JOYSTICK TILT to REVERSE.

Note

The setting above only changes the control signal from the unit, and does not change the setting of the camera itself.

Zoom control

The camera zoom can be operated using either the ZOOM ring on the top of the joystick or the ZOOM lever in the lens control block.

You can set which is used to control the zoom using CONFIG >RM SETUP >ZOOM in the RM menu.

For details about configuration, see "RM SETUP" (page 73).

You can adjust the zoom speed using the ZOOM SPEED knob on the lens control block.

To control the zoom using the ZOOM ring on the top of the joystick

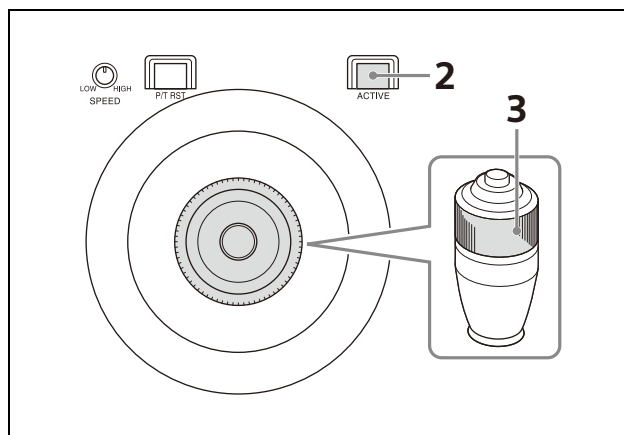

- 1 Select the target camera to control.**
For details about selection, see “Selecting a Camera” (page 34).
- 2 Press the ACTIVE button, turning it on (button is lit), on the joystick control block.**
- 3 Turn the ZOOM ring on the top of the joystick counterclockwise/clockwise.**
Release the joystick to stop zooming.

Turning the ZOOM SPEED knob clockwise increases the zoom speed, and turning counterclockwise decreases the zoom speed.

You can change the direction of the zoom lever using CONFIG >DIRECTION in the RM menu (page 74).

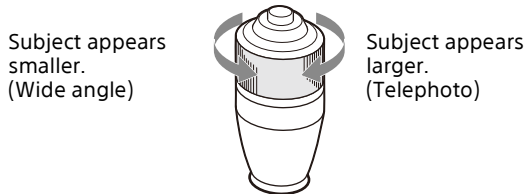

Note

When you perform pan/tilt operation while the camera is in telephoto mode, the speed of movement of the image on the screen may appear erratic.

To control the zoom using the ZOOM lever on the lens control block

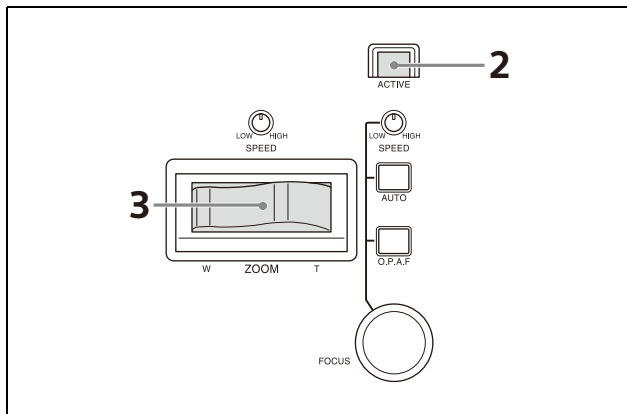

- 1 Select the target camera to control.**
For details about selection, see “Selecting a Camera” (page 34).
- 2 Press the ACTIVE button, turning it on (button is lit), on the lens control block.**
- 3 Move the ZOOM lever left/right.**
Moving the lever to the left makes the subject appear smaller (Wide angle).
Moving the lever to the right makes the subject appear larger (Telephoto).
The zoom speed changes depending on the pressure applied to the lever and the setting of the ZOOM SPEED knob.

Adjusting a Camera (excluding ILME-FR7)

The functions that can be operated vary depending on the camera model and configuration. For details, see "Function of Buttons/Knobs in Each Block by Camera Model" (page 64).

Adjusting the focus

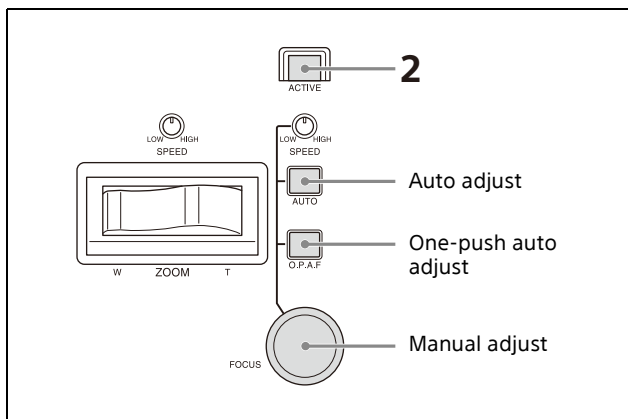

- 1 Select the target camera to control.**
For details about selection, see "Selecting a Camera" (page 34).
- 2 Press the ACTIVE button, turning it on (button is lit), on the lens control block.**
The lens control block becomes enabled.

To adjust the focus automatically

Press the AUTO FOCUS mode button, turning it on (button is lit yellow).
Auto focus mode is activated.
In auto focus mode, the camera focuses on the subject in the center of the screen automatically.

To adjust the focus manually

Press the AUTO FOCUS mode button, turning it off (button is not lit). Turn the FOCUS knob counterclockwise/clockwise to adjust the focus while monitoring the image of the subject.
The focus speed is set using the FOCUS SPEED knob. Turning the knob clockwise increases the focus speed, and turning counterclockwise decreases the focus speed.

One-push auto focus during manual focus adjustment

Press the O.P.A.F (one-push auto focus) button. The button blinks yellow for a few seconds, and then the camera focuses on the subject in the center of the screen automatically.

Adjusting the brightness

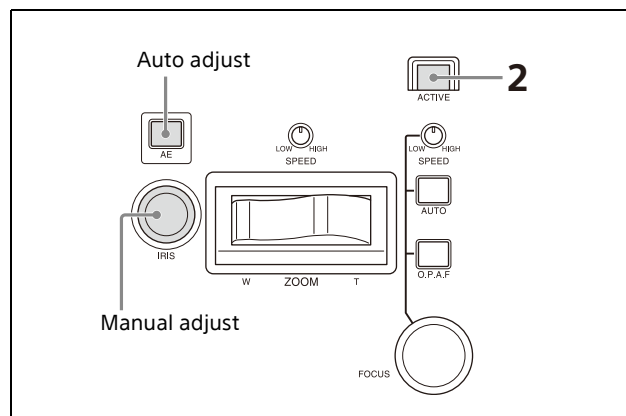

- 1 Select the target camera to control.**
For details about selection, see "Selecting a Camera" (page 34).
- 2 Press the ACTIVE button, turning it on (button is lit), on the lens control block.**

To adjust the exposure automatically

Press the AE button, turning it on (button is lit).

To adjust the exposure manually

- 1 Set CONFIG >RM SETUP >AE CONFIG to MANUAL or IRIS Pri in the RM menu.**
For details about AE CONFIG, see "AE CONFIG" (page 73).
- 2 Press the AE button, turning it off (button is not lit).**
- 3 Turn the IRIS knob to adjust the iris of the camera.**

To operate using IRIS, GAIN, and SHUTTER buttons

- 1 Set CONFIG >RM SETUP >AE CONFIG to MANUAL, IRIS Pri, GAIN Pri, or SHUTTER Pri in the RM menu.**
For details about AE CONFIG, see "AE CONFIG" (page 73).

- 2 Press the AE button, turning it off (button is not lit).**
- 3 Press the IRIS, GAIN, or SHUTTER button on the menu control block.**
The setting is displayed on the LCD panel and can be adjusted using the VALUE knob (FUNCTION menu).
For details about the FUNCTION menu, see "Setting Specific Functions using Shortcuts (excluding ILME-FR7)" (page 59).

Backlight compensation (BACKLIGHT)

Use the following procedure to compensate for backlighting if the subject appears dark due to a light source behind the subject. Backlight compensation functions when AE mode is enabled (AE button is lit). For details about function assignments to assign buttons, see "Assigning Functions to Assign Buttons" (page 51).

- 1 Select the target camera to control.**
For details about selection, see "Selecting a Camera" (page 34).
- 2 Press the ACTIVE button, turning it on (button is lit), on the color adjustment block.**
- 3 Press the assign button (ASSIGN 1 to ASSIGN 3) with the backlight compensation function assignment.**
BACKLIGHT is displayed highlighted on the bottom of the LCD panel of the unit when the button is pressed.

To cancel backlight compensation

Press the same assign button, turning it off (button is not lit).

Note

On the BRC-H900, to turn the AE button off, also turn this function off.

Flicker compensation (FLICKER)

Use the following procedure if there is any flicker in the image of the subject due to the effects of fluorescent lighting or other light sources. For details about function assignments to assign buttons, see "Assigning Functions to Assign Buttons" (page 51).

- 1 Select the target camera to control.**
For details about selection, see "Selecting a Camera" (page 34).
- 2 Press the ACTIVE button, turning it on (button is lit), on the color adjustment block.**
- 3 Press the assign button (ASSIGN 1 to ASSIGN 3) with the flicker compensation function assignment.**
FLICKER is displayed highlighted on the bottom of the LCD panel of the unit when the button is pressed.

To cancel flicker compensation

Press the same assign button, turning it off (button is not lit).

Adjusting the white balance

Position a white object under the same lighting conditions as the subject you want to shoot, and zoom in on it on the screen. (You can use a white wall or other object.) The white balance is adjusted against the white object.

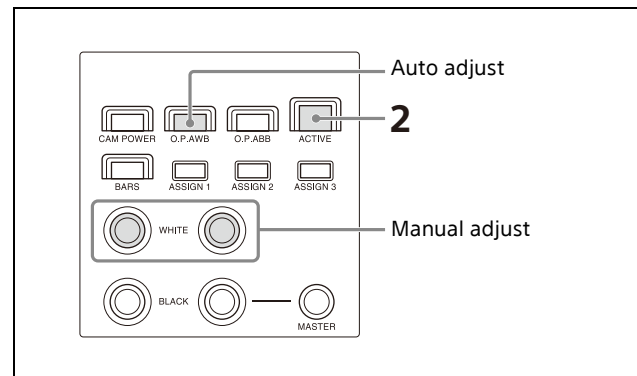

- 1 Select the target camera to control.**
For details about selection, see "Selecting a Camera" (page 34).
- 2 Press the ACTIVE button, turning it on (button is lit), on the color adjustment block.**

To adjust the white balance automatically

1 Set OPERATION >WHITE >WB MODE in the RM menu.

For details about settings, see “WB MODE” (page 69).

- Setting to AUTO1 or AUTO2 automatically adjusts the white balance according to the corresponding setting.
- Setting to ONE PUSH enables the O.P.AWB (one-push auto white balance) button.

2 If ONE PUSH is selected in step 1, press the O.P.AWB (one-push auto white balance) button.

The button blinks red for a few seconds, and then the camera white balance is adjusted automatically.

To adjust the white balance manually

1 Set OPERATION >WHITE >WB MODE to MANUAL in the RM menu.

For details about settings, see “WHITE” (page 69).

2 Adjust the white balance using the R-WHITE knob and B-WHITE knob.

Adjust the red gain using the R-WHITE knob, and the blue gain using the B-WHITE knob. Turning the knob counterclockwise decreases the red/blue hue, and turning clockwise increases the red/blue hue.

Adjusting the black balance

Adjust the black balance when you use a camera for the first time or after a long time of non-use, or if the ambient temperature of the camera has changed significantly.

Note

Check that OPERATION >BLACK >ABB MODE is set to ON in the RM menu. The black balance function cannot be executed if ABB MODE is set to OFF.

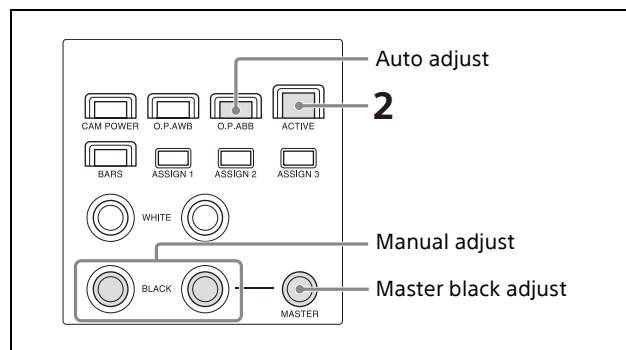

1 Select the target camera to control.

For details about selection, see “Selecting a Camera” (page 34).

2 Press the ACTIVE button, turning it on (button is lit), on the color adjustment block.

3 Adjust the black balance automatically or manually.

To adjust the black balance automatically

1 Set OPERATION >BLACK >ABB MODE to ON in the RM menu.

2 Press the O.P.ABB (one-push auto black balance) button.

The button blinks red for a few seconds, and then the camera black balance is adjusted automatically.

To adjust the black balance manually

Adjust the black balance using the R-BLACK knob and B-BLACK knob.

Adjust the R-BLACK value using the R-BLACK knob, and the B-BLACK value using the B-BLACK knob.

Turning the knob counterclockwise decreases the R-BLACK/B-BLACK value, and turning clockwise increases the R-BLACK/B-BLACK value.

To adjust the master black

1 Set the M.BLACK value using OPERATION >BLACK in the RM menu.

2 Adjust the master black using the MASTER BLACK knob.

Turning the knob counterclockwise decreases the master black level, and turning clockwise increases the master black level.

Adjusting a Camera (ILME-FR7)

The button/knob names used in the panel surface diagrams are the names when the panel sheet for ILME-FR7 is used.

Adjusting the focus

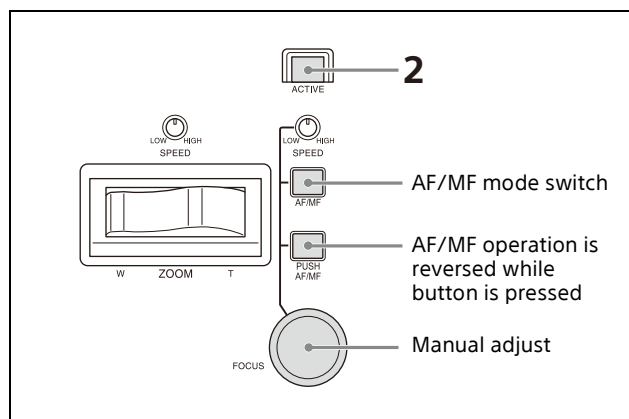

- 1 Select the target camera to control.**
For details about selection, see “Selecting a Camera” (page 34).
- 2 Press the ACTIVE button, turning it on (button is lit), on the lens control block.**
The lens control block becomes enabled.

To adjust the focus automatically

Press the AF/MF button, turning auto focus on (button is lit yellow).
While the Push AF/MF button is pressed, auto focus operation stops (push manual focus).
During auto focus operation, you can change the focus target manually by turning the FOCUS knob (AF Assist).
You can also use the joystick to move the auto focus target area (focus area) and select a face detection frame. See “Operating with the Screen Display Overlaid on the Camera Image (CAM GUI Operation Mode) (ILME-FR7)” (page 50).
For details about the focus functions, refer to the Help Guide of the camera.

To adjust the focus manually

Press the AF/MF button, turning auto focus off (button is not lit), and adjust the focus manually using the FOCUS knob. The focus speed is set using the FOCUS SPEED knob.

While the Push AF/MF button is pressed, auto focus operates (push auto focus (AF/AF-S)).

Tip

You can perform more accurate operation using the Web App of the camera. For details, refer to the Help Guide of the camera.

Adjusting the brightness

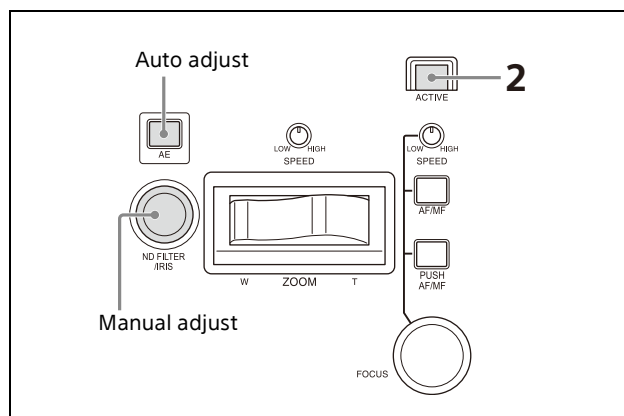

- 1 Select the target camera to control.**
For details about selection, see “Selecting a Camera” (page 34).
- 2 Press the ACTIVE button, turning it on (button is lit), on the lens control block.**

To adjust the exposure automatically

Press the AE button, turning it on (button is lit).
Setup items used for auto adjustment are configured using CONFIG >RM SETUP >AE CONFIG2 in the RM menu.
However, some items may not switch to automatic adjustment depending on the status of the camera.
For details, see “To select items used for automatic exposure compensation” (page 42).

To adjust the exposure manually

- 1 Press the AE button, turning it off (button is not lit).**
The ND filter, iris, ISO/gain, and shutter are all set manually.
- 2 Turn the IRIS knob to adjust the iris of the camera.**

You can also set the ND filter as the target of IRIS knob operation. For details, see “To operate the ND filter using the IRIS knob” (page 42).

To operate using IRIS, ISO/GAIN, and SHUTTER buttons

Press the IRIS, ISO/GAIN, or SHUTTER button in the menu control block to highlight the corresponding value on the camera image and turn the VALUE knob to adjust the value. For details, see "Setting Specific Functions using Shortcuts (ILME-FR7)" (page 60).

To operate using an ASSIGN button assigned with ND filter or exposure compensation function

Press an ASSIGN 4 to ASSIGN 6 button assigned with ND FILTER or AE LEVEL in the menu control block to highlight the corresponding value on the camera image and turn the VALUE knob to adjust the value.

For details, see "Setting Specific Functions using Shortcuts (ILME-FR7)" (page 60).

You can also assign other functions. For details, see "Assigning Functions to Assign Buttons" (page 51) and refer to the Help Guide of the camera.

Examples of adjustment functions that can be assigned on the ILME-FR7

- ND Filter
- ND Filter Position
- Auto ND Filter
- Push Auto ND Filter
- Auto Iris
- Push Auto Iris
- Base ISO/Sensitivity
- AGC
- Push AGC
- Auto Shutter
- AE Level / Mode
- Spotlight
- Backlight

To operate the ND filter using the IRIS knob

You can set the ND filter as the target of IRIS knob operation in the lens control block. Set the ND filter of the camera to variable mode beforehand using the camera menu.

- 1 Press the RM MENU button, turning it on (button is lit yellow).**
The RM menu top menu appears.
- 2 Turn the SELECT knob to move the cursor to CONFIG, and press the SELECT button.**
The CONFIG menu appears.

- 3 Turn the SELECT knob to move the cursor to SW ASSIGN, and press the SELECT button.**

The assign button setup menu appears.

- 4 Turn the SELECT knob to move the cursor to IRIS KNOB.**

- 5 Turn the VALUE knob to select ND&CLEAR or ND FILTER, and press the VALUE knob.**

When ND&CLEAR is selected, turning the knob quickly in the direction to increase the brightness beyond ND1/4 switches to CLEAR. Turning the knob quickly in the direction to decrease the brightness from CLEAR switches to ND1/4.

When ND FILTER is selected, to switch between CLEAR and ND On, press and hold the ND FILTER button assigned to ASSIGN 4 to ASSIGN 6 for menu operation, or use ND Filter Position on a camera assignable button.

To return to iris operation, select IRIS in step 5. On cameras other than the ILME-FR7, iris operation occurs regardless of this setting.

To select items used for automatic exposure compensation

You can set automatic adjustment of the ND filter, iris, ISO/gain, or shutter by pressing the AE button in the lens control block to turn on automatic exposure compensation (button is lit).

- 1 Press the RM MENU button, turning it on (button is lit yellow).**
The RM menu top menu appears.
- 2 Turn the SELECT knob to move the cursor to CONFIG, and press the SELECT button.**
The CONFIG menu appears.
- 3 Turn the SELECT knob to move the cursor to RM SETUP, and press the SELECT button.**
The RM setup menu appears.
- 4 Turn the SELECT knob to move the cursor to AE CONFIG2.**
- 5 Turn the VALUE knob to select a setting, and press the VALUE knob.**
The following abbreviations indicate the supported options.
N: ND filter
I: Iris
G: ISO/gain
S: Shutter

This setting sets the item to which the auto exposure command is sent when the AE button light is switched on. Some items may not switch to automatic adjustment depending on the status of the camera.

Example:

- When a lens that does not support auto iris adjustment is attached
- When the ND filter is set to preset mode or CLEAR

Prepare the camera beforehand. For details, refer to the Help Guide of the camera.

You can also switch between automatic and manual operation for each item regardless of this setting. For details, see “Setting Specific Functions using Shortcuts (ILME-FR7)” (page 60).

Adjusting the white balance

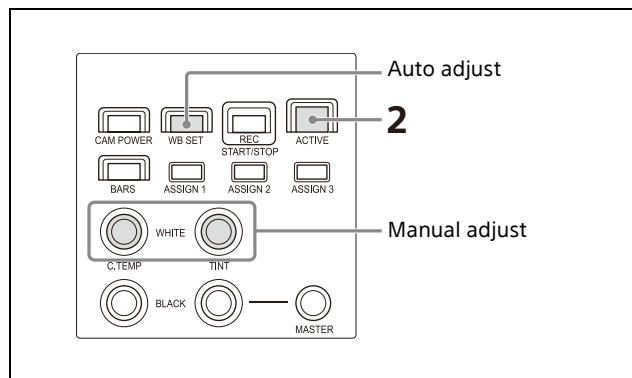

- 1 Select the target camera to control.**
For details about selection, see “Selecting a Camera” (page 34).
- 2 Press the ACTIVE button, turning it on (button is lit), on the color adjustment block.**

To adjust the white balance automatically (ATW (auto tracking white balance))

You can set OPERATION >WHITE >WB MODE to ATW in the RM menu to smoothly adjust the white balance automatically in response to changes in the image. Or press the WB SET button to adjust the white balance immediately. During ATW, you can use the C.TEMP knob and TINT knob to operate Offset White to shift the hue.

For details about ATW operation and Offset White, refer to the Help Guide of the camera.

Note

Before using ATW, check the setting for Offset White<ATW> in the camera menu. It is recommended that all settings be set back to ±0 after use.

To adjust the white balance automatically (auto white balance)

Position a white object under the same lighting conditions as the subject you want to shoot, and zoom in on it on the screen. (You can use a white wall or other object.)

The white balance is adjusted against the white object.

- 1 Set OPERATION >WHITE >WB MODE to MEM.A T/T or MEM.A R/B in the RM menu.**
- 2 Press the WB SET button to run white balance.**
The button blinks red for a few seconds, then the result of automatic adjustment is saved the mode returns to manual adjustment state.

To adjust the white balance manually

- 1 Set OPERATION >WHITE >WB MODE to MEM.A T/T, MEM.A R/B, or PRESET in the RM menu.**
- 2 Adjust the white balance using the C.TEMP/R-WHITE knob and TINT/B-WHITE knob.**
When WB MODE is set to PRESET, you can adjust the color temperature only.
When WB MODE is set to MEM.A T/T, you can adjust the color temperature and the tint.
When WB MODE is set to MEM.A R/B, you can adjust the red and blue gain.

Adjusting the black balance

Adjust the black balance when you use a camera for the first time or after a long time of non-use, or if the ambient temperature of the camera has changed significantly.

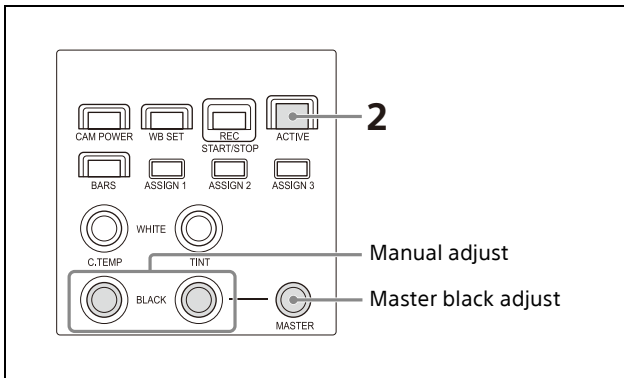

- 1 Select the target camera to control.**
For details about selection, see “Selecting a Camera” (page 34).
- 2 Press the ACTIVE button, turning it on (button is lit), on the color adjustment block.**
- 3 Adjust the black balance using the R-BLACK knob and B-BLACK knob.**
Adjust the R-BLACK value using the R-BLACK knob, and the B-BLACK value using the B-BLACK knob.

To adjust the master black

- 1 Set the M.BLACK value using OPERATION >BLACK in the RM menu.**
- 2 Adjust the master black using the MASTER BLACK knob.**
Turning the knob counterclockwise decreases the master black level, and turning clockwise increases the master black level.

Recording Video to a Memory Card (ILME-FR7)

On the ILME-FR7, you can record video to a memory card inserted in the camera.

- 1 Insert a memory card in the camera.**
For details about preparation for recording, refer to the Help Guide of the camera.
- 2 Press the REC START/STOP button in the color adjustment block of the unit.**
The camera starts recording and the button lights up red.

To stop recording, press the REC START/STOP button again. Recording stops and the button turns off (not lit).

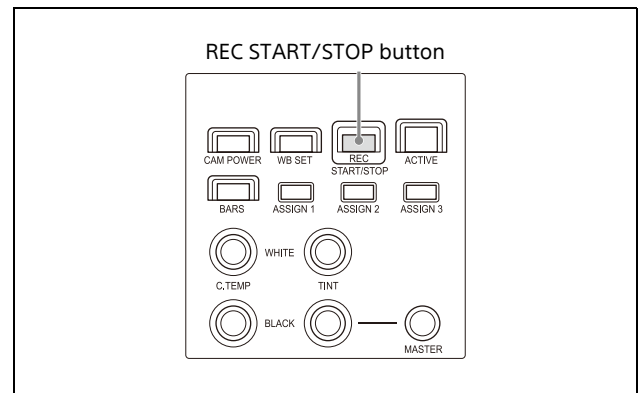

To play back the memory card video

- 1 Set each of Thumbnail and Slot Select to one of the assignable buttons (ASSIGN 1 to ASSIGN 9) of the camera, and assign each to an assign button of the unit.**
For details about assign buttons, see “Assigning Functions to Assign Buttons” (page 51).
- 2 Press the assign button that was assigned with Thumbnail in step 1.**
The thumbnail screen with the clips recorded on the memory card is output as the camera image. Press the [Slot Select] button to switch between memory cards.
- 3 Select the clip you want to play back in CAM GUI operation mode.**
For details about CAM GUI operation, see “Operating with the Screen Display Overlaid

on the Camera Image (CAM GUI Operation Mode) (ILME-FR7)” (page 50).
 For details about playback operation, refer to the Help Guide of the camera.

Storing the Camera Status (Preset Function)

The camera status, comprising the camera position, zooming, focusing, backlighting compensation, flicker compensation, and white/black balance adjustments, can be stored in the memory of the camera.

Note

On the ILME-FR7, only the camera position, zoom, and focus adjustment status are saved.

You can set the speed of movement between positions for memory preset operation using OPERATION >OTHER >PRST SPEED in the RM menu. This setting is applied to all presets. The speed of movement default setting is 24. The number of presets varies depending on the camera. For details, refer to the specifications for the camera.

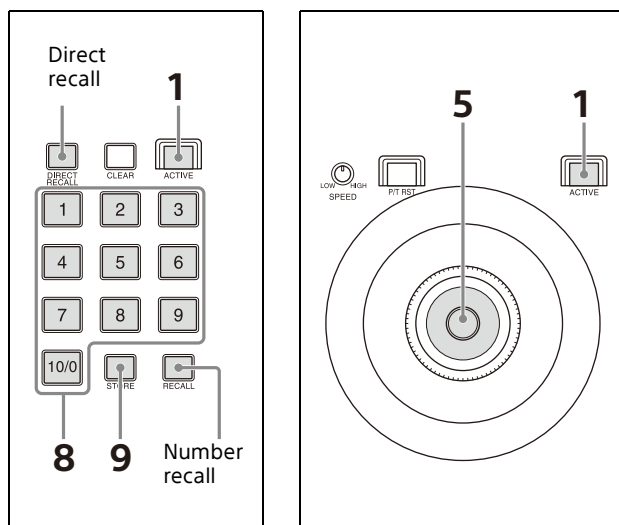

- 1** Press the **ACTIVE** button, turning it on (button is lit), on the joystick control block and preset memory control block.
- 2** Select the camera whose status you want to store.
 For details about selection, see “Selecting a Camera” (page 34).

Note

For a target camera other than an ILME-FR7, if “PRST:TRACE” is displayed at the bottom of the LCD panel, press an assign button to change to preset mode to MODE1 or MODE2.

Each time you press an assign button, the preset mode switches between MODE1/ MODE2 and TRACE. MODE1 is selected when "PRST:MODE1" is displayed on the LCD panel. MODE2 is selected when "PRST:MODE2" is displayed.

Not displayed on cameras that do not support switching the preset mode.

For details about function assignments to assign buttons, see "Assigning Functions to Assign Buttons" (page 51).

- 3 Operate the joystick to pan/tilt the orientation of the camera.**
- 4 Perform zoom, focus, backlight compensation, flicker compensation, and white/black balance adjustments, as required.**
- 5 Check that the DIRECT RECALL button is off.**
If the button is on (button lit yellow), turn it off (button not lit).
- 6 Enter the preset number you want to store.**
Use the PRESET 10/0 button to enter a "0" digit.
The maximum number that can be saved varies depending on the camera.
The preset number is displayed at the bottom right on the LCD panel of the menu control block.
- 7 Press and hold the STORE button.**
The camera status is stored in the memory of the camera.
The preset number at the bottom right of the LCD panel is displayed highlighted, and storing is completed when the display disappears.

After registering a preset, we recommend that you check that the camera status is stored correctly by recalling the preset.

Recalling stored status

There are two methods for recalling stored status: direct recall and number recall. Pressing and holding the CLEAR button cancels the recall operation and stops the camera at its current position.

Direct recall

With the DIRECT RECALL button on (button is lit yellow), press the PRESET 1 to PRESET 10/0 buttons to recall preset numbers 1 to 10. Only preset numbers 1 to 10 can be recalled using direct recall.

Number recall

With the DIRECT RECALL button off (button is not lit), enter the preset number using the PRESET 1 to PRESET 10/0 buttons, in the same way as when storing a preset, and then press the RECALL button.

In this method, the entered preset number is displayed at the bottom right on the LCD panel of the menu control block.

Preset numbers 1 to 100 can be recalled using number recall.

Changing the speed of movement between positions

- 1 Check that the DIRECT RECALL button is off.**
If the button is on (button lit yellow), turn it off (button not lit).
- 2 Select a camera, and recall the position you want to change.**
- 3 Set the speed using OPERATION >OTHER >PRST SPEED in the RM menu.**
- 4 Press and hold the STORE button.**

Note

Subsequently when a preset is stored, the speed of movement between positions changes to the value set in step 3.

Recording the Pan/Tilt/Zoom Operation of a Camera (Trace Function)

This function records the pan/tilt/zoom operation of a camera in order to reproduce (trace) those actions later as required. The BRC-X1000 and BRC-H800 cameras with firmware version 2.0 or later support this function. Up to 16 patterns can be recorded.

Note

This function is not supported for the ILME-FR7.

Recording the pan/tilt/zoom operation

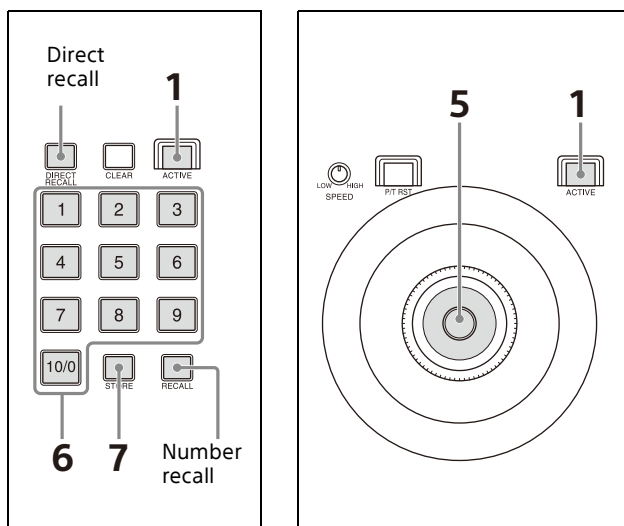

1 Press the **ACTIVE** button, turning it on (button is lit), on the joystick control block and preset memory control block.

2 Select the camera whose status you want to store.

For details about selecting a camera, see "Selecting a Camera" (page 34).

Note

If "PRST:MODE1" or "PRST:MODE2" is displayed at the bottom of the LCD panel, press an assign button to change the preset mode to TRACE.

Each time you press an assign button, the preset mode switches between MODE1,

MODE2, and TRACE. TRACE is selected when "PRST:TRACE" is displayed on the LCD panel. For details about function assignments to assign buttons, see "Assigning Functions to Assign Buttons" (page 51).

3 Operate the joystick to pan/tilt the orientation of the camera.

4 Check that the **DIRECT RECALL** button is off.

If the button is on (button lit yellow), turn it off (button not lit).

5 Enter the preset number you want to store. Use the PRESET 10/0 button to enter a "0" digit.

The maximum number that can be saved varies depending on the camera.

The preset number is displayed at the bottom right on the LCD panel of the menu control block.

6 Press and hold the **STORE** button.

Recording of each operation starts.

REC is displayed highlighted to the right of PRST:TRACE at the bottom of the LCD panel during recording.

7 Perform the pan/tilt/zoom operations you want to record.

8 To stop recording, press the button on the top of the joystick. Alternatively, re-enter the preset number entered in step 5, and press and hold the **STORE** button.

The REC indicator disappears.

Starting playback of a recorded trace

Use one of the following methods to start playback of a recorded trace.

Direct recall

With the **DIRECT RECALL** button on (button is lit yellow), you press the PRESET 1 to PRESET 10/0 button in which the operations were recorded to start playback of the trace. Only preset numbers 1 to 10 can be recalled using direct recall.

1 Check that the preset mode is set to **TRACE**.

- 2 Press the preset button in which the operations were recorded.**
The camera orientation is set to the position at the start of the trace.
- 3 Press and hold the same preset button.**
Playback of the recorded trace operations starts.

Number recall

With the DIRECT RECALL button off (button is not lit), you enter the preset number using the PRESET 1 to PRESET 10/0 buttons and then press the RECALL button to start playback of a trace.

- 1 Check that the preset mode is set to TRACE.**
- 2 Enter the preset button in which the operations were recorded.**
The entered preset number is displayed at the bottom right of the LCD panel of the menu control block.
- 3 Press the RECALL button.**
The camera orientation is set to the position at the start of the trace.
- 4 Enter the same preset number, and press and hold the RECALL button.**
Playback of the recorded trace operations starts.

Note

When the target camera is switched by both the GPI I/O connector and NORMAL TALLY mode setting, the trace operation of the previous camera stops at the same time. For details about GPI I/O and TALLY MODE settings, see page 34 and page 75.

Operating the Camera Setup Menu from the Unit (Camera Menu Operation Mode) (excluding ILME-FR7)

You can operate the setup menu on the camera using the knobs and buttons on the menu control block and the joystick.

Notes

- In camera menu operation mode, the menu is displayed on the monitor output of the camera. Nothing is displayed on the LCD panel of the unit.
- Operation according to the camera specifications is required to save settings.

Buttons and knobs used for camera menu operations

Operation	Buttons and knobs used
Activate camera menu mode.	Press and hold the CAM MENU button.
Select a setup menu item.	Turn the SELECT knob or tilt up/down using the joystick.
Confirm the setup menu item selection.	Press the SELECT button or the joystick button.
Select a setup menu sub item.	Turn the SELECT knob or pan left/right using the joystick.
Change the setting of the setup menu sub item.	Turn the VALUE knob or press the joystick button.
Confirm the changed setting.	
Save settings.	Saved on the camera using the camera preset memory function.*
Go back one level in the menu.	Press and hold the CAM MENU button or press the CANCEL button.

* For details about items saved with a preset number, refer to the operating instructions for the camera.

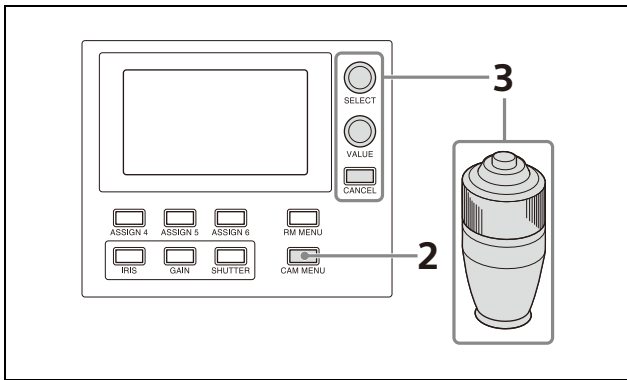

- 1 Select the target camera to control.**
For details about selection, see “Selecting a Camera” (page 34).
- 2 Press and hold the CAM MENU button, turning it on (button is lit yellow).**
Camera menu operation mode is activated. The camera setup menu is displayed on the output video monitor for the camera on-screen display.
- 3 Operate the camera setup menu using the SELECT knob/button, VALUE knob, CANCEL button, and joystick.**

SELECT knob

Selects menu items.
The cursor moves up/down as the SELECT knob is turned counterclockwise/clockwise.

SELECT button (or VALUE button)

Press this button to confirm the selection of menu items.
If a menu item has sub items, those sub items are displayed.

VALUE knob

Selects settings.
The setting changes as the VALUE knob is turned counterclockwise/clockwise.

CANCEL button

Press this button to go back one level in the menu and to exit the setup menu.

Note

On the SRG series and BRC-X400/X401, pressing the CANCEL button during menu operation will exit menu mode. To go up one level in the menu, press and hold the CAM MENU button.

Operation using the joystick

Select a setup menu item using tilt operation, and select the setting using pan operation.
Press the joystick button to confirm the selection of items and settings.

- 4 Exit camera setup menu mode.**
Press the CANCEL button repeatedly until the menu disappears.

Operating with the Screen Display Overlaid on the Camera Image (CAM GUI Operation Mode) (ILME-FR7)

For an ILME-FR7 target camera, you can use the joystick to operate the following camera functions using a screen display overlaid on the camera image (CAM GUI operation mode).

- Camera menu operations
- Message operations with buttons
- Recorded clip thumbnail selection/playback operations
- Focus area frame/face/eye selection cursor movement during auto focus

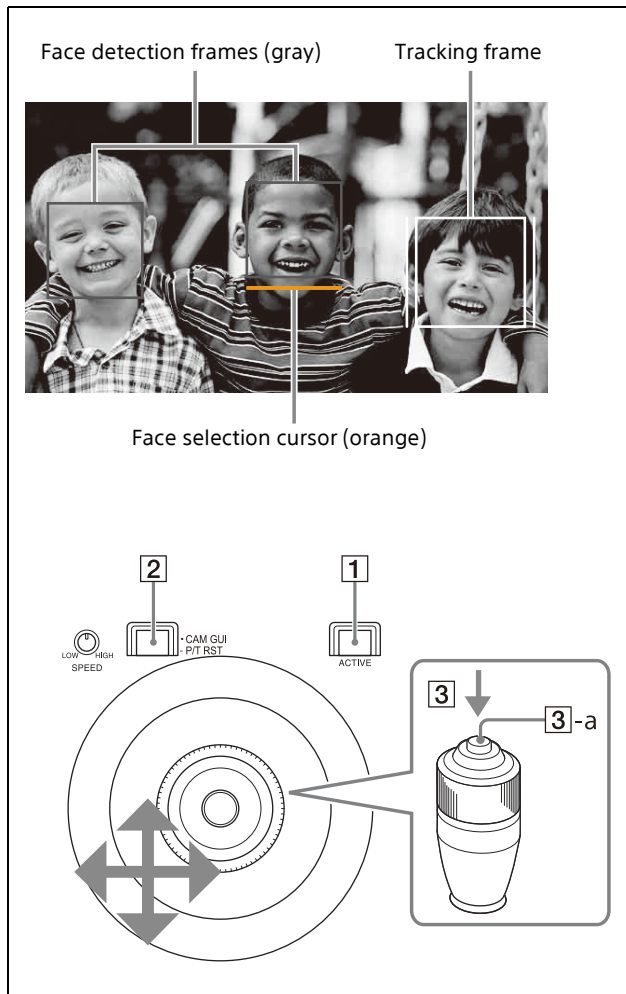

1 Press the **1** ACTIVE button, turning it on (button is lit), on the joystick control block.

2 Press the **2** CAM GUI / P/T RST button, turning it on (button is lit). The joystick switches to CAM GUI operation mode.

3 Operate the camera GUI using the joystick. The operation of the **3**-a joystick button is the apply operation (SET button operation defined by the camera).

4 When finished, press the **2** CAM GUI / P/T RST button, turning it off (button is not lit). The joystick operation returns to pan/tilt operation.

To operate the camera menu

To show/hide the camera menu, press and hold the CAM MENU button.

When two or more of the IRIS button, ISO/GAIN button, and SHUTTER button light up blue, "MULTI FUNCTION DIAL" is displayed on the LCD panel and the camera GUI can be controlled using the SELECT knob and button or the VALUE knob and button (multi-function dial mode).

When the camera menu is not displayed, press the SELECT button or VALUE button to activate direct menu operation on the shooting screen. For details about direct menu operation, refer to the Help Guide of the camera.

Assigning Functions to Assign Buttons

The functions in the following table can be assigned to the ASSIGN 1, ASSIGN 2, and ASSIGN 3 buttons of the color adjustment block and the ASSIGN 4, ASSIGN 5, and ASSIGN 6 buttons of the menu control block.

If the target camera is equipped with a variable ND filter, you can also assign the ND filter to the IRIS knob.

Functions that can be assigned to the ASSIGN 1, ASSIGN 2, and ASSIGN 3 buttons

Function	LCD display
Backlight compensation	BACKLIGHT
Flicker compensation	FLICKER
Status display	STATUS
Clear Image Zoom ^{*1}	CIZ
Teleconverter ^{*1}	TELE CONV
Preset mode switch (MODE 1) ^{*1}	MOD1-TRCE
Preset mode switch (MODE 2) ^{*1}	MOD2-TRCE
Screen display switch ^{*1}	DISPLAY
Camera assignable button ^{*1*2}	ASSIGN 1 to ASSIGN 9
Lens FOCUS HOLD button ^{*1*2}	FOCUS HLD
PTZ Auto Framing	PTZ AUTO

*1 For details about target cameras, see "Function of Buttons/Knobs in Each Block by Camera Model" (page 64).

*2 For an ILME-FR7, you can assign an assignable button function from the camera to an assign button of this unit and then operate the camera indirectly.

Functions that can be assigned to the ASSIGN 4, ASSIGN 5, and ASSIGN 6 buttons

Function	LCD display
DETAIL level	DETAIL LEVEL
Knee point	KNEE
Exposure compensation level	AE LEVEL
ND filter ^{*1}	ND FILTER
Picture profile ^{*1}	P PROFILE
Audio input level ^{*1}	AUDIO LVL
Camera assignable button ^{*1*2}	ASSIGN 1 to ASSIGN 9
Lens FOCUS HOLD button ^{*1*2}	FOCUS HLD

*1 For details about target cameras, see "Function of Buttons/Knobs in Each Block by Camera Model" (page 64).

*2 For an ILME-FR7, you can assign an assignable button function from the camera to an assign button of this unit and then operate the camera indirectly.

Functions that can be assigned to the IRIS knob

If the target camera is equipped with a variable ND filter, you can also assign variable ND filter operations to the IRIS knob.

If the target camera does not have a variable ND filter, iris operation is active regardless of this setting.

For details about the set value and selection options, see "To operate the ND filter using the IRIS knob" (page 42).

Use the following procedure to assign a function.

- 1 Press the RM MENU button, turning it on (button is lit yellow).**
The RM menu top menu appears.
- 2 Turn the SELECT knob to move the cursor to CONFIG, and press the SELECT button.**
The CONFIG menu appears.
- 3 Turn the SELECT knob to move the cursor to SW ASSIGN, and press the SELECT button.**
The assign button setup menu appears.

```
< SW ASSIGN >
→ ASSIGN1 : BACKLIGHT
  ASSIGN2 : FLICKER
  ASSIGN3 : STATUS
  ASSIGN4 : DETAIL
  ASSIGN5 : KNEE
  ASSIGN6 : AE LEVEL
  IRIS KNOB : IRIS
  PRST : TRACE
```

- 4 Turn the SELECT knob to move the cursor to the name of the assign button or knob you want to assign a function.**
- 5 Turn the VALUE knob to select a function, and press the VALUE knob.**
The function is assigned to the assign button/IRIS knob.

Checking the function assigned to an assign button

When an ASSIGN 1 to ASSIGN 6 button is pressed, the name of the function assigned to the button is displayed highlighted on the bottom of the LCD panel for a few seconds.

To operate camera/lens assignable button functions (ILME-FR7)

You can assign an assignable button function from the camera to an assign button of this unit and then operate the camera indirectly.

Assignment example

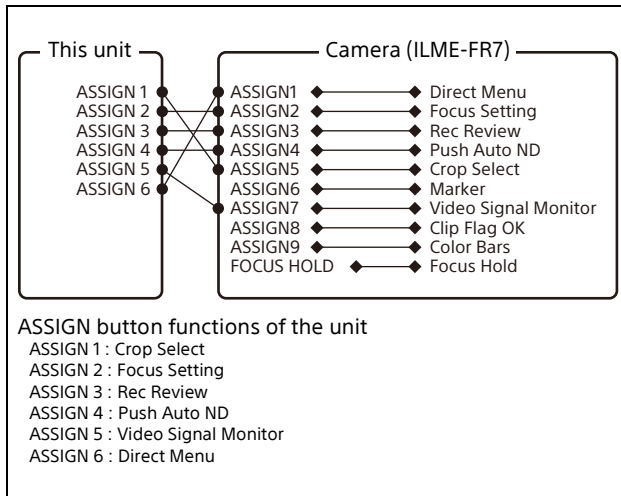

Recommended Settings for ILME-FR7 Operation

For an ILME-FR7 target camera, you can operate the camera efficiently by assigning functions for operations beforehand.

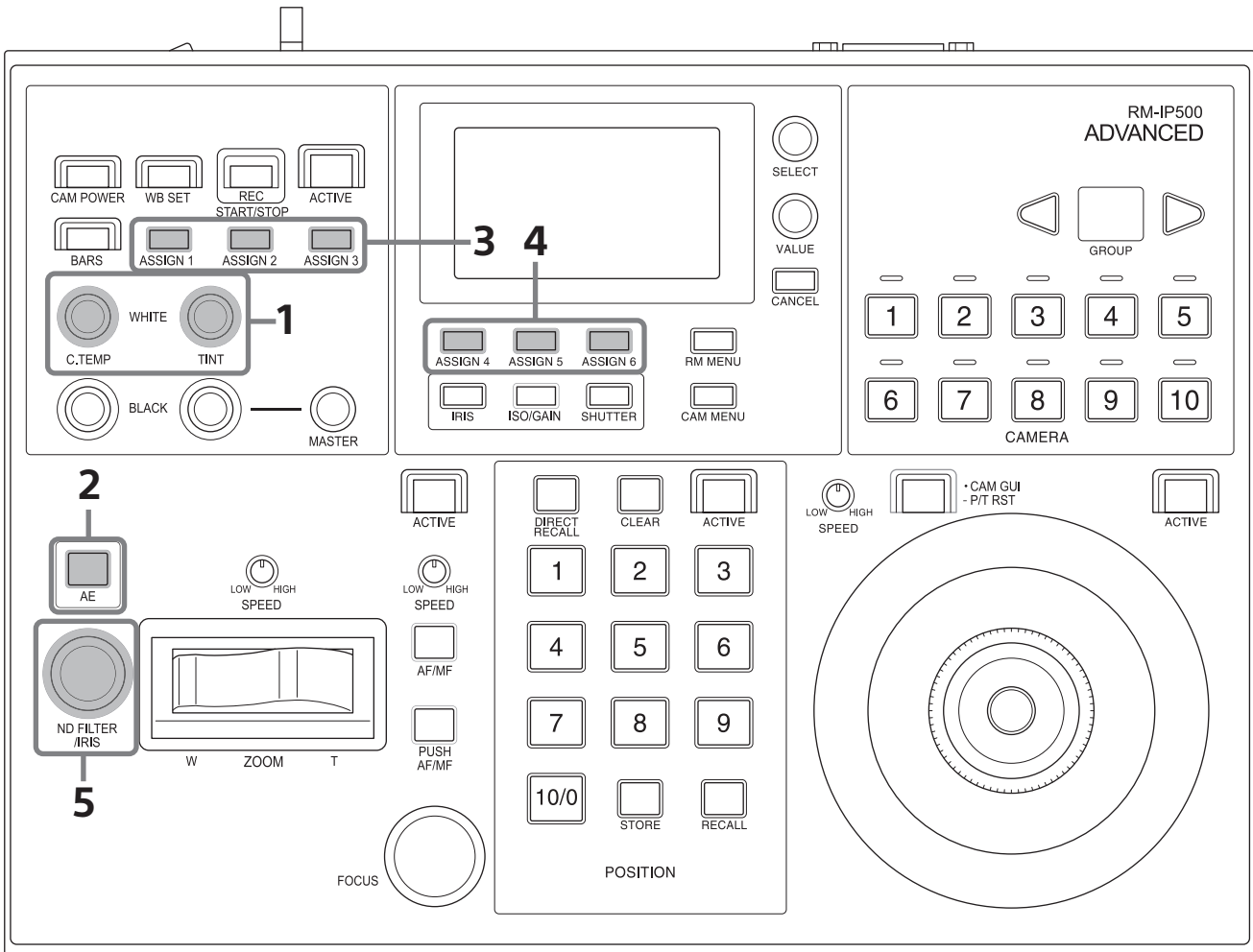

Button/knob	Function assignment menu item
1	OPERATION > WHITE > WB MODE
2	CONFIG > RM SETUP > AE CONFIG2
3	CONFIG > SW ASSIGN > ASSIGN1
	CONFIG > SW ASSIGN > ASSIGN2
	CONFIG > SW ASSIGN > ASSIGN3
4	CONFIG > SW ASSIGN > ASSIGN4
	CONFIG > SW ASSIGN > ASSIGN5
	CONFIG > SW ASSIGN > ASSIGN6
5	CONFIG > SW ASSIGN > IRIS KNOB

The following sections describe example recommended settings.

Recommended setting 1

This setting is recommended for fine exposure adjustment using the iris and using AE when appropriate.

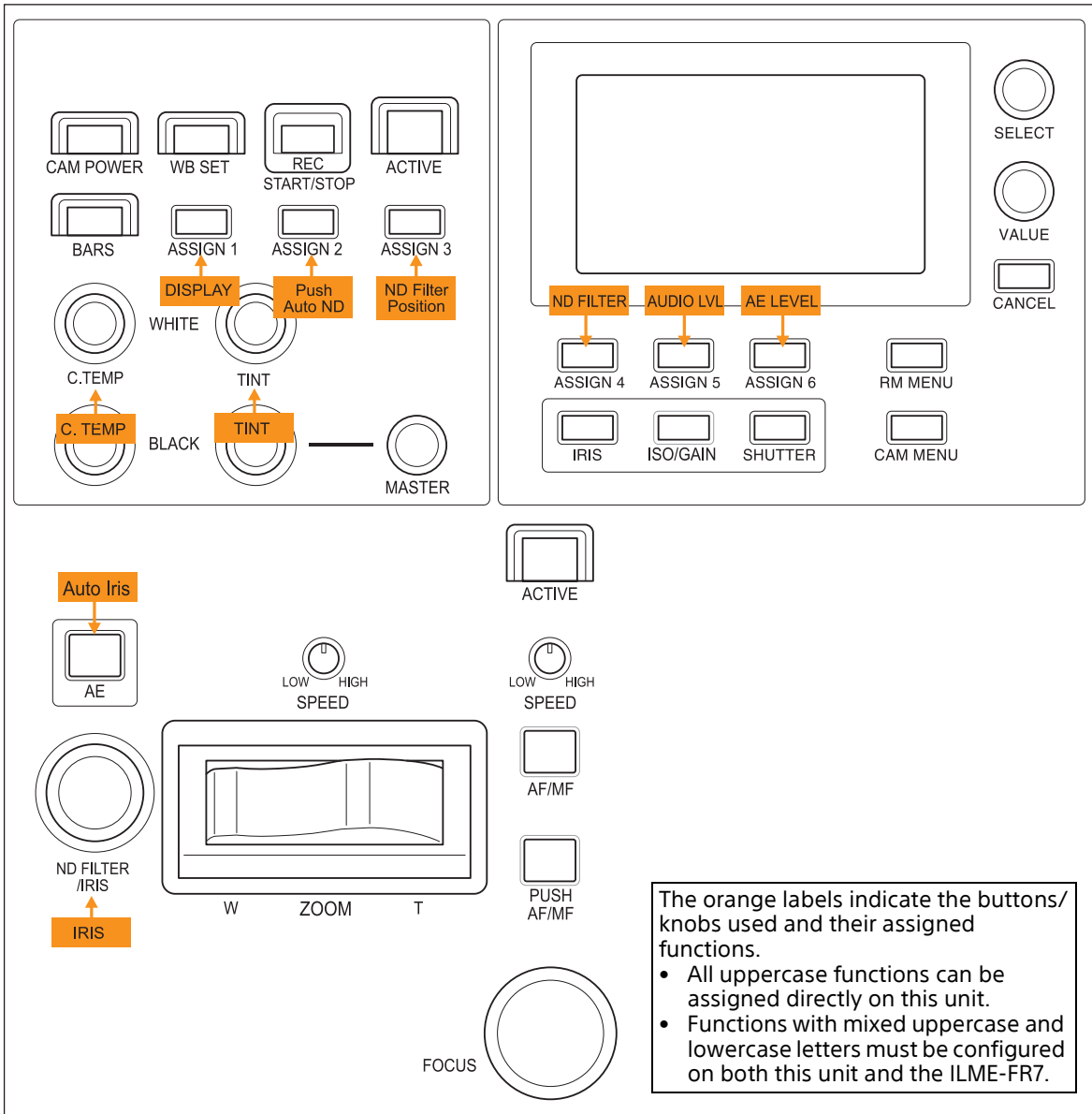

Assignment table

Function assignment menu item	Setting of the unit	ILME-FR7 assignable button function assignment
OPERATION > WHITE > WB MODE	MEM.A T/T	-
CONFIG > RM SETUP > AE CONFIG2	IRIS	-
CONFIG > SW ASSIGN > ASSIGN1	DISPLAY	-
CONFIG > SW ASSIGN > ASSIGN2	ASSIGN 4	Push Auto ND
CONFIG > SW ASSIGN > ASSIGN3	ASSIGN 9	ND Filter Position
CONFIG > SW ASSIGN > ASSIGN4	ND FILTER	-
CONFIG > SW ASSIGN > ASSIGN5	AUDIO LVL	-
CONFIG > SW ASSIGN > ASSIGN6	AE LEVEL	-
CONFIG > SW ASSIGN > IRIS KNOB	IRIS	-

Recommended setting 2

This setting is recommended for fine exposure adjustment using the ND filter and using AE when appropriate.

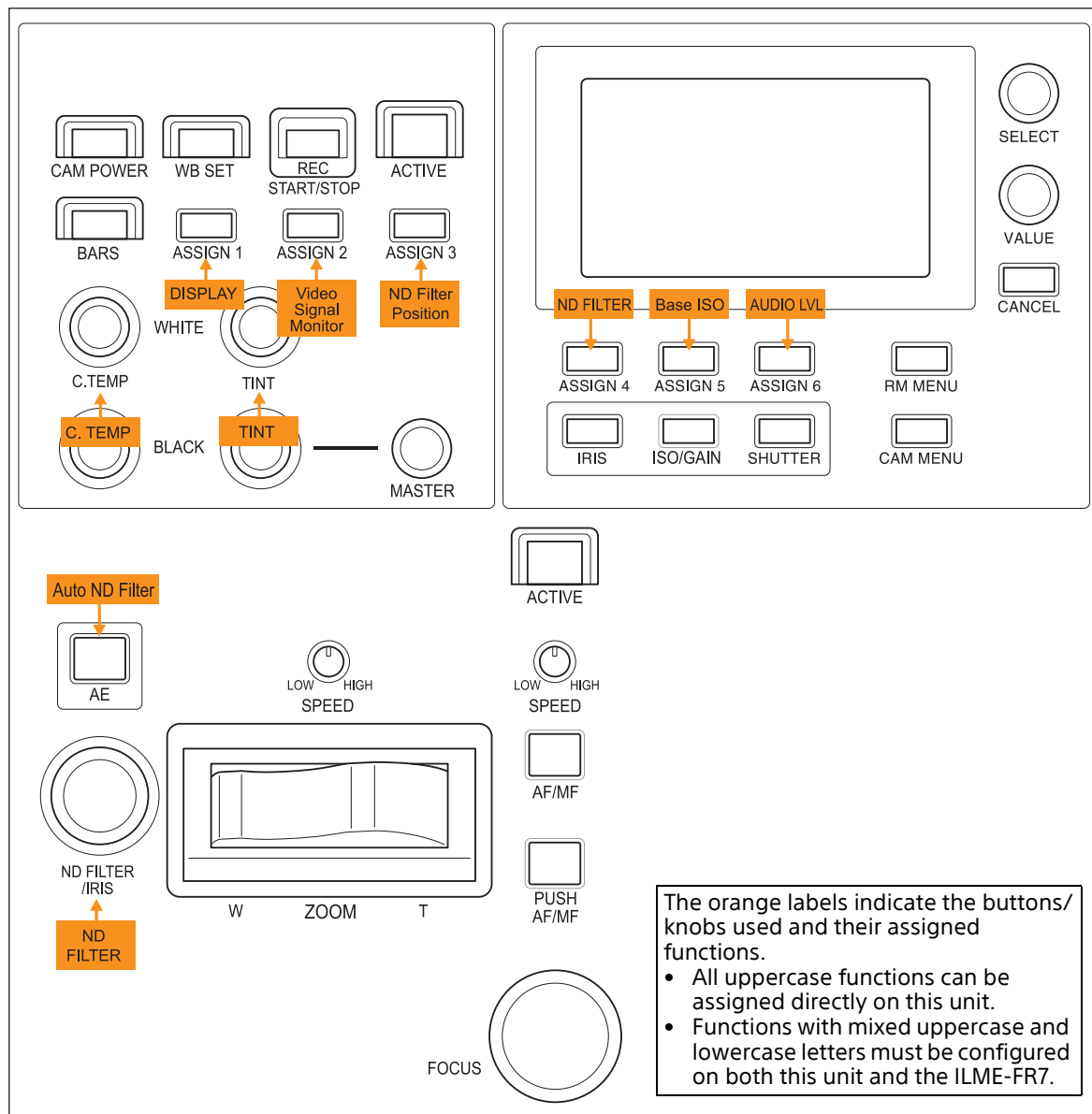

Assignment table

Function assignment menu item	Setting of the unit	ILME-FR7 assignable button function assignment
OPERATION > WHITE > WB MODE	MEM.A T/T	-
CONFIG > RM SETUP > AE CONFIG2	ND FILTER	-
CONFIG > SW ASSIGN > ASSIGN1	DISPLAY	-
CONFIG > SW ASSIGN > ASSIGN2	ASSIGN 7	Video Signal Monitor
CONFIG > SW ASSIGN > ASSIGN3	ASSIGN 9	ND Filter Position
CONFIG > SW ASSIGN > ASSIGN4	ND FILTER	-
CONFIG > SW ASSIGN > ASSIGN5	ASSIGN 6	Base ISO/Sensitivity
CONFIG > SW ASSIGN > ASSIGN6	AUDIO LVL	-
CONFIG > SW ASSIGN > IRIS KNOB	ND FILTER	-

Recommended setting 3

This setting is recommended when actively using AE.

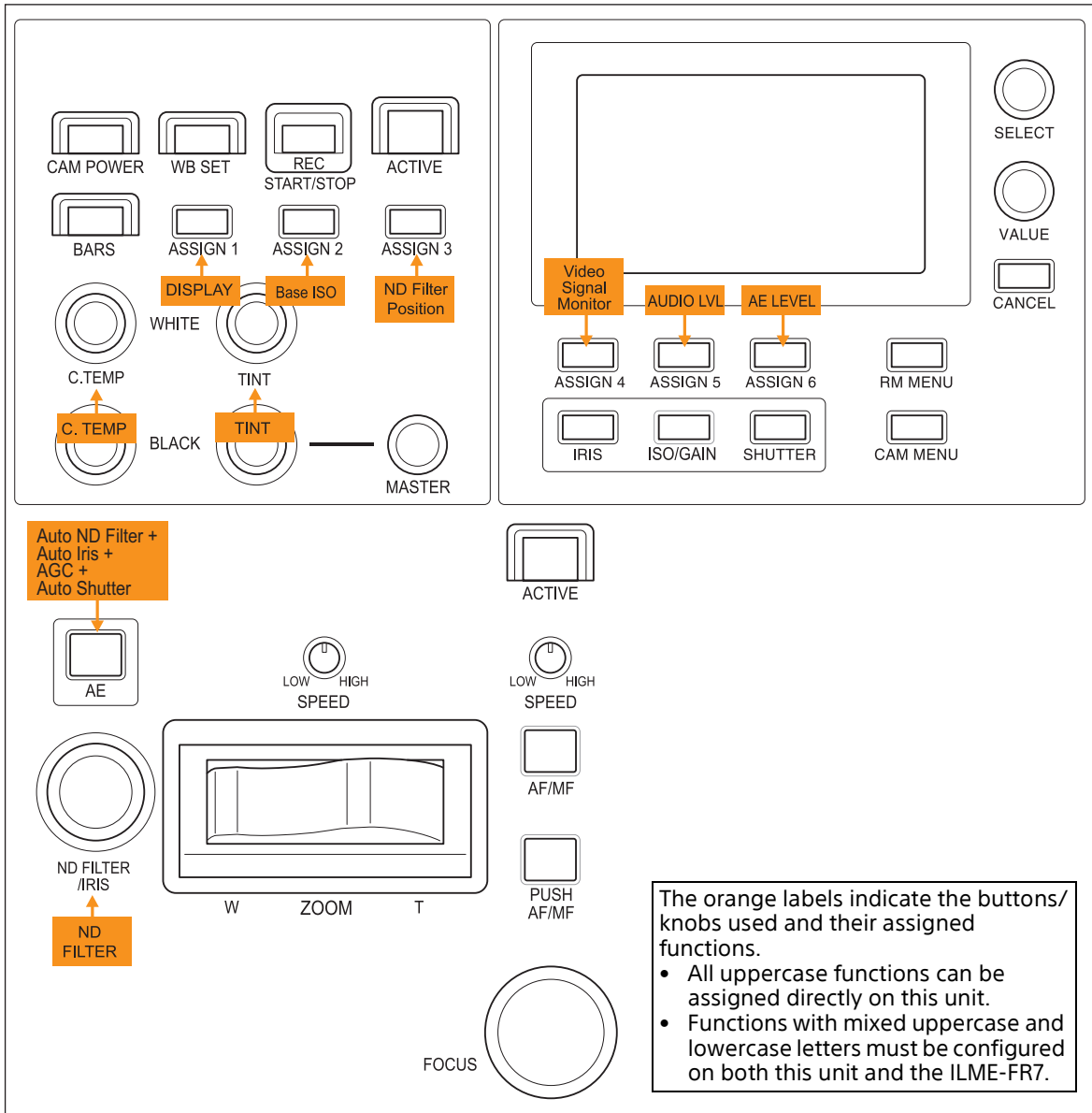

Assignment table

Function assignment menu item	Setting of the unit	ILME-FR7 assignable button function assignment
OPERATION > WHITE > WB MODE	MEM.A T/T	-
CONFIG > RM SETUP > AE CONFIG2	ALL	-
CONFIG > SW ASSIGN > ASSIGN1	DISPLAY	-
CONFIG > SW ASSIGN > ASSIGN2	ASSIGN 6	Base ISO/Sensitivity
CONFIG > SW ASSIGN > ASSIGN3	ASSIGN 9	ND Filter Position
CONFIG > SW ASSIGN > ASSIGN4	ASSIGN 7	Video Signal Monitor
CONFIG > SW ASSIGN > ASSIGN5	AUDIO LVL	-
CONFIG > SW ASSIGN > ASSIGN6	AE LEVEL	-
CONFIG > SW ASSIGN > IRIS KNOB	ND FILTER	-

Recommended setting 4

This setting is recommended when the priority is Cine EI operations and AE is not used in principle. Set the ILME-FR7 shooting mode to Cine EI mode.

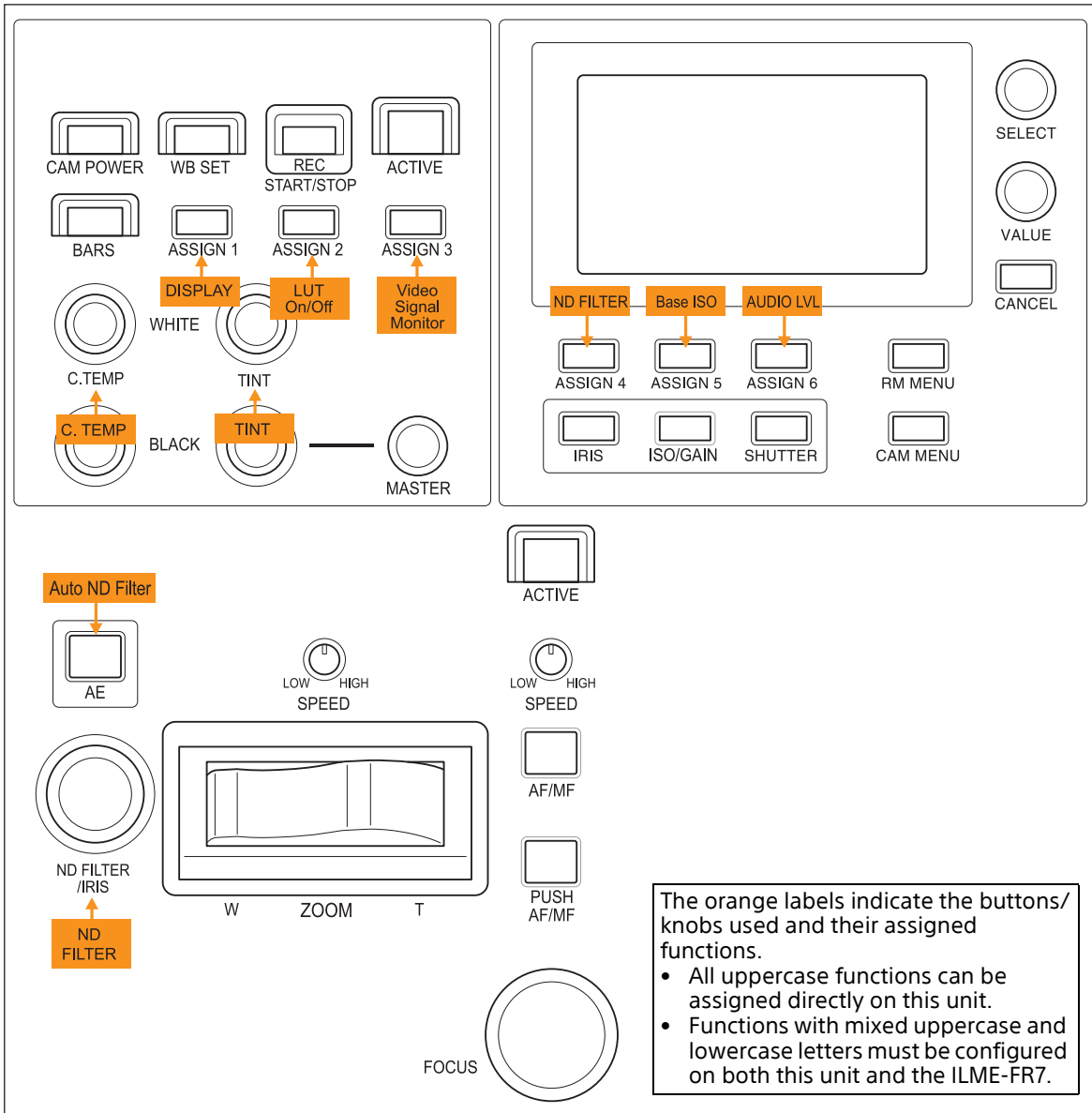

Assignment table

Function assignment menu item	Setting of the unit	ILME-FR7 assignable button function assignment
OPERATION > WHITE > WB MODE	MEM.A T/T	-
CONFIG > RM SETUP > AE CONFIG2	ND FILTER	-
CONFIG > SW ASSIGN > ASSIGN1	DISPLAY	-
CONFIG > SW ASSIGN > ASSIGN2	ASSIGN 9	LUT On/Off
CONFIG > SW ASSIGN > ASSIGN3	ASSIGN 7	Video Signal Monitor
CONFIG > SW ASSIGN > ASSIGN4	ND FILTER	-
CONFIG > SW ASSIGN > ASSIGN5	ASSIGN 6	Base ISO/Sensitivity
CONFIG > SW ASSIGN > ASSIGN6	AUDIO LVL	-
CONFIG > SW ASSIGN > IRIS KNOB	ND FILTER	-

Recommended setting 5

This setting is recommended when the priority is live operations and using AE when appropriate. Set the ILME-FR7 shooting mode to Custom mode.

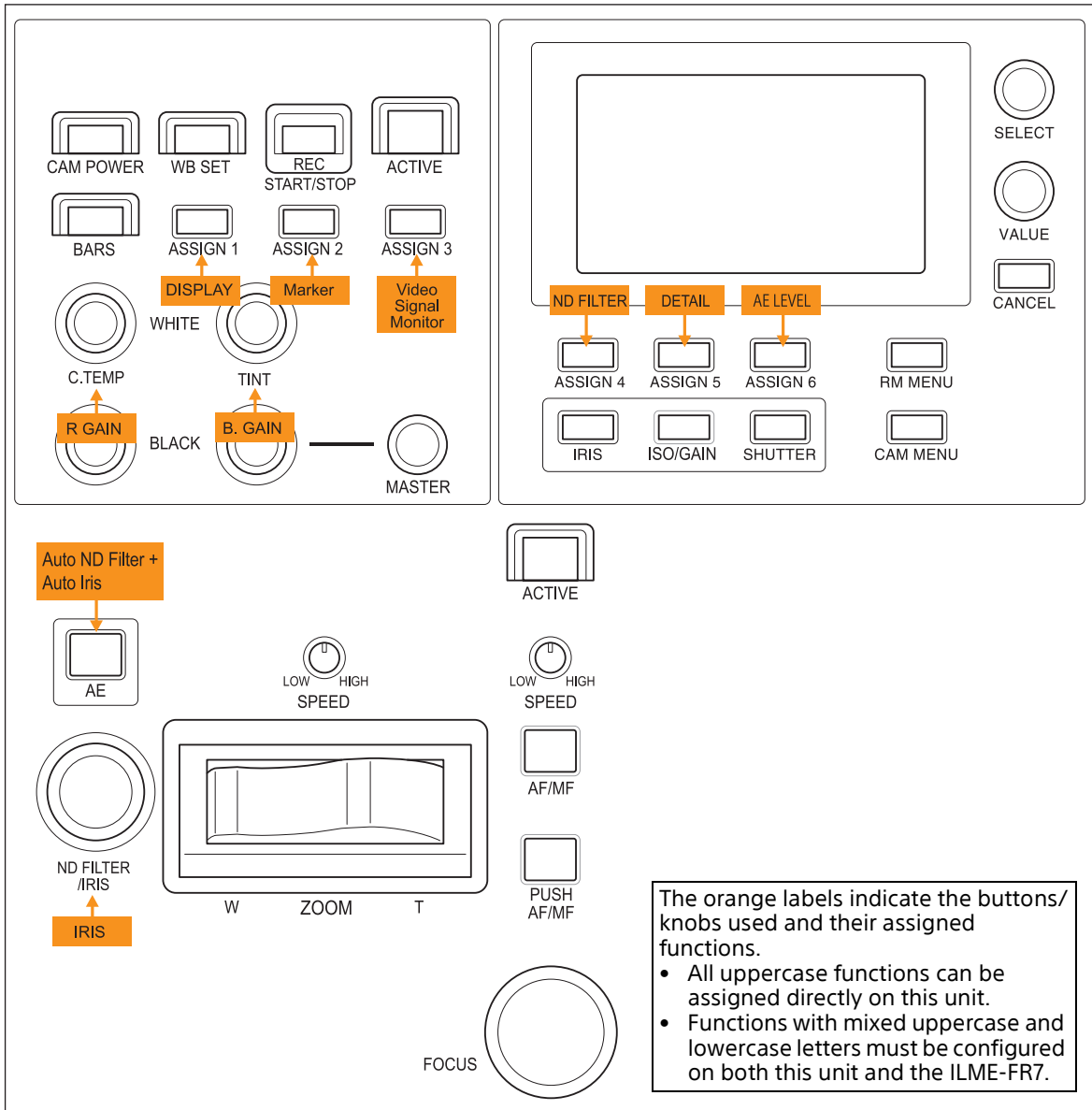

Assignment table

Function assignment menu item	Setting of the unit	ILME-FR7 assignable button function assignment
OPERATION > WHITE > WB MODE	MEM.A R/B	–
CONFIG > RM SETUP > AE CONFIG2	ND+IRIS	–
CONFIG > SW ASSIGN > ASSIGN1	DISPLAY	–
CONFIG > SW ASSIGN > ASSIGN2	ASSIGN 6	Marker
CONFIG > SW ASSIGN > ASSIGN3	ASSIGN 7	Video Signal Monitor
CONFIG > SW ASSIGN > ASSIGN4	ND FILTER	–
CONFIG > SW ASSIGN > ASSIGN5	DETAIL	–
CONFIG > SW ASSIGN > ASSIGN6	AE LEVEL	–
CONFIG > SW ASSIGN > IRIS KNOB	IRIS	–

Setting Specific Functions using Shortcuts (excluding ILME-FR7)

When the IRIS, GAIN, SHUTTER, ASSIGN 4, ASSIGN 5, or ASSIGN 6 button is pressed on the menu control block, the setup item and setting of the function assigned to the button is displayed on the LCD panel. You can change the setting using the VALUE knob (FUNCTION menu). This allows you to set some functions more quickly than by using normal menu operations.

Notes

- Depending on the camera model, the settings displayed on the unit and camera menu display may not be the same. In this case, the settings displayed in the camera menu are the actual settings.
- When changing a setting, there may be some delay before the display is updated.

Buttons and knobs used for FUNCTION menu operations

Operation	Buttons and knobs used
Activate FUNCTION menu mode.	Press the IRIS, GAIN, SHUTTER, or ASSIGN 4 to ASSIGN 6 button.
Change the setting of the setup menu sub item.	Turn the VALUE knob. Confirmation of changed settings is not required.
Save settings.	Saved on the camera using the camera preset memory function.*

* For details about items saved with a preset number, refer to the operating instructions for the camera.

Operation using IRIS, GAIN, and SHUTTER buttons

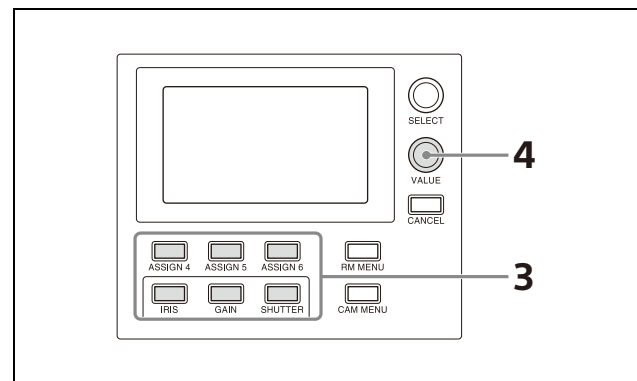

- 1 Set CONFIG >RM SETUP >AE CONFIG to MANUAL, IRIS Pri, GAIN Pri, or SHUTTER Pri in the RM menu.**
For details about AE CONFIG, see "AE CONFIG" (page 73).
- 2 Press the AE button, turning it off (button is not lit).**
The IRIS, GAIN, or SHUTTER button operation which is enabled (lit blue) is determined by the AE CONFIG setting.
- 3 Press the IRIS, GAIN, or SHUTTER button.**
The button is lit yellow, and the adjustment item and setting are displayed on the LCD panel.
- 4 Set the value using the VALUE knob.**

Note

If an adjustment is not supported, "---" is displayed for the adjustment value.

IRIS button

Sets the iris value of the camera.

GAIN button

Sets the gain value of the camera.

SHUTTER button

Sets the shutter speed of the target camera. The settings display varies depending on the frame rate setting (59.94 Hz or 50 Hz). For details about the frame rate setting, see CAMERA FREQ (page 74).

Operation using ASSIGN 4, ASSIGN 5, and ASSIGN 6

Press ASSIGN 4, ASSIGN 5, or ASSIGN 6. The button is lit yellow, and the adjustment item and setting of the function assigned to the button is displayed on the LCD panel.

For details about function assignments to assign buttons, see “Assigning Functions to Assign Buttons” (page 51).

Setting Specific Functions using Shortcuts (ILME-FR7)

When the IRIS, GAIN, SHUTTER, ASSIGN 4, ASSIGN 5, or ASSIGN 6 button is pressed on the menu control block, the setup item and setting of the function assigned to the button is displayed on the LCD panel or camera image. You can change the setting using the VALUE knob (FUNCTION menu or multi-function dial mode).

This allows you to set some functions more quickly than by using normal menu operations.

Note

To use functions displayed on the camera image, set the camera to superimpose the screen display on the image output used for operating this unit.

Target buttons/functions		LCD display	Setting display destination
Dedicated buttons	Iris	IRIS	Camera image
	ISO/gain	ISO/GAIN	Camera image
	Shutter	SHUTTER	Camera image
ASSIGN 4 to ASSIGN 6 buttons*1	DETAIL level	DETAIL LEVEL	LCD panel
	Knee point	KNEE	LCD panel
	Exposure compensation	AE LEVEL	Camera image
	ND filter	ND FILTER	Camera image
	Audio input level	AUDIO LVL	LCD panel
	Camera assignable button	ASSIGN 1 to ASSIGN 9	Camera image
	Lens FOCUS HOLD button	FOCUS HOLD	Camera image

*1 Picture profile is not supported on the ILME-FR7.

Operating the DETAIL level, knee point, or audio input level

- 1 Assign functions to use to ASSIGN 4 to ASSIGN 6.**
For details about function assignments to assign buttons, see “Assigning Functions to Assign Buttons” (page 51).
- 2 Press a button assigned with a function.**
- 3 For AUDIO LVL, select the item to set using the SELECT knob.**
- 4 Change the setting using the VALUE knob.**

Note

If configuration is not supported, “---” is displayed for the setting.

Operating the iris, ISO/gain, shutter, ND filter, or exposure compensation

To operate the ND filter or exposure compensation, assign ND FILTER or AE LEVEL to any of ASSIGN 4 to ASSIGN 6 buttons beforehand. For details about function assignments to assign buttons, see “Assigning Functions to Assign Buttons” (page 51). In this section, the IRIS button, ISO/GAIN button, and SHUTTER button are collectively referred to as function buttons.

- 1 Press a function button on the shooting screen.**
The setting for the selected function is displayed on a white background on the camera image screen display. Also, the IRIS button, ISO/GAIN button, and SHUTTER button, whichever is not pressed, light up blue, and “MULTI FUNCTION DIAL” is displayed on the LCD panel.
- 2 Change the setting using the VALUE knob.**

You can press and hold the button in step 1 to switch between automatic and manual adjustment and to display a menu for changing the mode.

When two or more of the IRIS button, ISO/GAIN button, and SHUTTER button light up blue, the camera GUI can be controlled using the SELECT knob and button or the VALUE knob and button (multi-function dial mode). When the camera

menu is not displayed, press the SELECT button or VALUE button to activate direct menu operation on the shooting screen. For details about direct menu operation, refer to the Help Guide of the camera.

Notes

- Function buttons are disabled during camera menu display. First, exit the camera menu.
- In cases such as when using multiple remote control devices for operation, the screen display as described in step 1 may not appear. Press the function button again until the desired screen display appears.

Operating camera/lens assignable button functions

Assign camera/lens assignable button functions to any of ASSIGN 4 to ASSIGN 6 beforehand. For details about function assignments to assign buttons of this unit, see “Assigning Functions to Assign Buttons” (page 51). For details about function assignments to camera/lens assignable buttons, refer to the operating instructions for the camera.

- 1 Press an assign button assigned with a function.**
The IRIS button, ISO/GAIN button, or SHUTTER button light up blue.
- 2 Operate the camera image screen display using the VALUE knob and button as required.**
When two or more of the IRIS button, ISO/GAIN button, and SHUTTER button light up blue, the camera GUI can be controlled using the SELECT knob and button or the VALUE knob and button (multi-function dial mode). When the camera menu is not displayed, press the SELECT button or VALUE button to activate direct menu operation on the shooting screen. For details about direct menu operation, refer to the Help Guide of the camera.

Note

Multi-function dial mode is not activated by ASSIGN 1 to ASSIGN 3 operation.

Checking Camera Settings Status (Status Display)

Press an assign button (ASSIGN 1 to ASSIGN 3) with the camera status display function assignment to display the current iris, gain, shutter speed, and zoom position status of the target camera on the LCD panel for about three seconds.

Note

This function is not supported for the ILME-FR7.

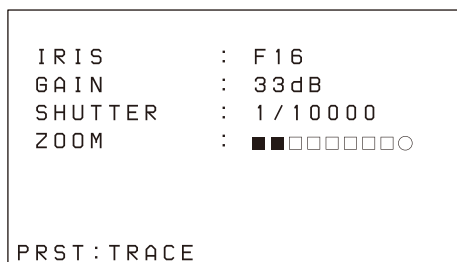
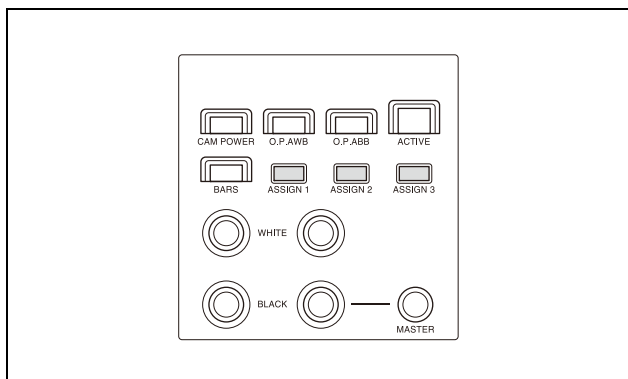

After approximately three seconds, the display automatically turns off.

ZOOM position indicator

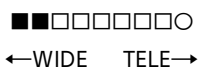

□ represents the divisions between the WIDE and TELE positions, while ■ represents the current position from the WIDE end. ○ indicates Clear Image Zoom and the digital zoom range. The indicator changes from ○ to ● when the camera zoom is in that range.

Restoring Factory Default Settings

You can restore all settings stored in the unit to their factory default values. This operation is performed using MAINTENANCE >RESET in the RM menu.

- 1 **Press the RM MENU button, turning it on (button is lit yellow).**
The RM menu top menu appears.
- 2 **Turn the SELECT knob to move the cursor to MAINTENANCE.**
- 3 **Press the SELECT button.**
The MAINTENANCE menu appears.
- 4 **Turn the SELECT knob to select RESET.**
The RESET screen appears.
- 5 **Turn the SELECT knob to move the cursor to RESET ALL.**
→RESET ALL : : NOT EXEC
- 6 **Turn the VALUE knob to change NOT EXEC to EXEC, then press the VALUE button.**
The following message appears, prompting you to reboot the unit.
- 7 **Turn the VALUE knob to change NO to YES, then press the VALUE button.**

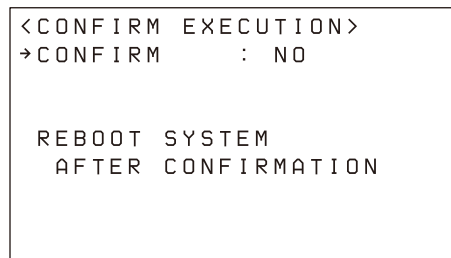

The unit reboots automatically.

Default values

The state of each control block on the control panel is given below.

- The ACTIVE button is on (button is lit) on the color adjustment block, lens control block, and preset memory control block.
- The DIRECT RECALL button is on (button is lit) on the preset memory control block.
- The CAMERA 1 button is on (button is lit yellow) on the camera selection block. "1" (group number 1) is displayed in the group number display.
- The RM MENU button is on (button is lit) in the menu control block, and the top menu is displayed on the LCD panel.

All camera information in the camera table is cleared, and the settings for camera information items are undefined.

The settings of all setup items in the RM menu are returned to their default values, shown in the following table.

Menu item	Sub menu item	Setup item	Default value	
OPERATION	WHITE	WB MODE	MEM.A T/T ^{*1}	
	OTHER	PRST SPEED	24	
CONFIG	RM SETUP	AE CONFIG	MANUAL	
		AE CONFIG2	ALL	
		CAM POWER	EACH	
		ZOOM	LEVER	
		CAMERA FREQ	59.94 ^{*2}	
		LCD BRIGHT	5	
		LAMP DIMMER	5	
	SW ASSIGN	ASSIGN1	BACKLIGHT	
		ASSIGN2	FLICKER	
		ASSIGN3	STATUS	
		ASSIGN4	DETAIL	
		ASSIGN5	KNEE	
		ASSIGN6	AE LEVEL	
	DIRECTION	IRIS KNOB	IRIS	
		JOYSTICK PAN	STANDARD	
		JOYSTICK TILT	STANDARD	
		ZOOM LEVER	STANDARD	
	GPI I/O	FOCUS DIAL	STANDARD	
		SETTING	INPUT	
		TALLY MODE	NORMAL	
		COMMAND SEL	STANDARD	
	LAN	CAMERA LINK	ON	
		IP	192.168.0.10	
		SM	255.255.255.0	
	SERIAL	GW	0.0.0.0	
		BAUD RATE	9600	
	CONTROL I/F		LAN	
	AUTO IP SETUP	SETUP IP	[FROM] IP	192.168.0.1
			[TO] IP	192.168.0.254
		ASSIGN CAM	[FROM] GROUP NUM	01
			[FROM] CAMERA NUM	01
MAINTENANCE	JOYSTICK	SENSITIVITY	5	

*1 ILME-FR7 only. When MEM.A is selected on the camera, the WHITE knob adjusts the color temperature and tint, respectively.

*2 Default value of 50 for models sold in China.

Function of Buttons/Knobs in Each Block by Camera Model

Cameras other than ILME-FR7

Yes: Supported
-: Not supported

Control block	Button/knob	Function	Conditions	BRC-X1000/ H800/H780/ X400/X401	BRC- H900	SRG series ^{*1}
Lens control block	AE button	Exposure mode selection	When the button is on (lit): Full auto. When the button is off (not lit): Follows CONFIG >RM SETUP >AE CONFIG setting in the RM menu.	Yes	Yes	Yes ^{*2}
	FOCUS adjustment knob	Manual focus adjustment	Enabled when the AUTO FOCUS mode button is not lit.	Yes	Yes	Yes
	O.P.A.F (one-push auto focus) button	One-push auto focus adjustment	Enabled when the AUTO FOCUS mode button is not lit.	Yes	Yes	Yes
	IRIS knob	Iris setting adjustment	Enabled when the AE button is not lit, and CONFIG >RM SETUP >AE CONFIG is set to MANUAL or IRIS Pri in the RM menu.	Yes	Yes	Yes
Color adjustment block	O.P.AWB (one-push auto white balance) button	One-push white balance auto adjustment	Enabled when OPERATION >WHITE >WB MODE is set to ONE PUSH in the RM menu.	Yes	Yes	Yes
	O.P.ABB (one-push auto black balance) button	One-push black balance auto adjustment	Enabled when OPERATION >BLACK >ABB MODE is set to ON in the RM menu.	-	Yes	-
	BARS button	Toggle color bars output on/off.	-	Yes ^{*12}	Yes	-
	ASSIGN 1 to ASSIGN 3 buttons	Toggle backlight compensation on/off.	Enabled when the AE button is lit.	Yes	Yes ^{*3}	Yes
		Toggle flicker compensation on/off.	Enabled when FLICKER CANCEL >MODE is set to ON in the camera menu.	Yes	Yes	-
		Display the status of the iris, gain, shutter speed, and zoom position.	-	Yes	Yes	Yes
		Toggle Clear Image Zoom on/off.	-	Yes ^{*8 *12}	-	Yes ^{*11}
		Toggle the teleconverter on/off.	-	Yes ^{*8 *12}	-	Yes ^{*13}
		Toggle preset mode (MOD1-TRCE, MOD2-TRCE)	-	Yes ^{*9}	-	-
Toggle PTZ auto framing on/off.		-	-	-	Yes ^{*14}	

Yes: Supported
 -: Not supported

Control block	Button/knob	Function	Conditions	BRC-X1000/ H800/H780/ X400/X401	BRC- H900	SRG series*1
Color adjustment block	R-WHITE knob/ B-WHITE knob	R gain and B gain adjustment	Enabled when OPERATION >WHITE >WB MODE is set to MANUAL in the RM menu.	Yes	Yes	Yes
	R-BLACK knob/ B-BLACK knob	R black and B black adjustment	Enabled when OPERATION >BLACK >ABB MODE is set to OFF in the RM menu.	-	Yes	-
	MASTER BLACK knob	Master black adjustment	-	Yes	-*4	-
FUNCTION menu of menu control block	ASSIGN 4 to ASSIGN 6 buttons	DETAIL LEVEL display	-	Yes	Yes	Yes*5
		Adjustment using VALUE knob after DETAIL LEVEL is displayed	On the BRC-H900, enabled if DETAIL is set to ON in the camera menu.			
		KNEE POINT display	-	Yes	Yes	-
		Adjustment using VALUE knob after KNEE POINT is displayed	Enabled when KNEE is set to ON in the camera menu, and KNEE MODE is set to MANUAL.			
		AE level display	Enabled when the AE button is lit, or if the AE button is not lit and CONFIG >RM SETUP >AE CONFIG is not set to MANUAL in the RM menu.	Yes	Yes	Yes
		Adjustment using VALUE knob after AE level is displayed	Enabled when OPERATION >EXPOSURE >EX-COMP is set to ON in the RM menu.			
		ND1 to ND 4 ND filter settings	-	Yes*8	-	-
	PP1 to PP6 picture profile settings	-	Yes*12	-	-	
	IRIS button (lit blue when enabled)	IRIS setting display	Enabled when the AE button is not lit.	Yes	Yes	Yes*15
		Adjustment using VALUE knob after IRIS setting is displayed	Enabled when the AE button is not lit, and CONFIG >RM SETUP >AE CONFIG is set to MANUAL or IRIS Pri in the camera menu.			
GAIN button (lit blue when enabled)	GAIN setting display	Enabled when the AE button is not lit.	Yes*10	Yes*6	Yes*6	
	Adjustment using VALUE knob after GAIN setting is displayed	Enabled when the AE button is not lit, and CONFIG >RM SETUP >AE CONFIG is set to MANUAL or GAIN Pri in the camera menu.				

Yes: Supported
 -: Not supported

Control block	Button/knob	Function	Conditions	BRC-X1000/ H800/H780/ X400/X401	BRC- H900	SRG series*1
FUNCTION menu of menu control block	SHUTTER button (lit blue when enabled)	Shutter speed display	Enabled when the AE button is not lit.	Yes*7	Yes*7	Yes*7
		Adjustment using VALUE knob after shutter speed is displayed	Enabled when the AE button is not lit, and CONFIG >RM SETUP >AE CONFIG is set to MANUAL or SHUTTER Pri in the camera menu.			

- *1 Target cameras: SRG-360SHE/280SHE, SRG-300SE/301SE/201SE, SRG-300H/301H, SRG-120DH/121DH/120DS/120DU/HD1, SRG-X400/201M2, SRG-X120/HD1M2, SRG-A40/A12, SRG-XB25, SRG-XP1
- *2 If the WIDE D(VIEW-DR) function exists in EXPOSURE >MODE >FULL AUTO in the camera menu and it is set to a setting other than OFF, FULL AUTO mode cannot be set to OFF using the AE button. To switch between AUTO and manual using the AE button, set WIDE D to OFF.
- *3 Enabled when Exposure Mode is set to FULL AUTO or BACK LIGHT in the camera menu.
- *4 Setting is enabled in the camera menu.
- *5 Except for SRG-X400/201M2, SRG-X120/HD1M2, and SRG-A40/A12, the APERTURE setting of the PICTURE menu on the camera is applied.
- *6 GAIN Pri cannot be selected.
- *7 Setting changes with the frame rate (50 Hz/59.94 Hz). Set CONFIG >RM SETUP >CAMERA FREQ in the RM menu to the frame rate setting of the camera.
- *8 Target cameras: BRC-X1000, BRC-H800, and BRC-H780 with firmware version 2.0 or later
- *9 Target cameras: BRC-X1000 and BRC-H800 with firmware version 2.0 or later
- *10 On the BRC-X400/X401, GAIN Pri cannot be selected.
- *11 Target cameras: SRG-X400/201M2/A40 (SRG-XB25/XP1 support PIXEL ZOOM on/off switching)
- *12 Target cameras: BRC-X400/X401
- *13 Target cameras: SRG-X401 and SRG-A40/A12
- *14 Target cameras: SRG-A40/A12
- *15 SRG-XP1 does not support iris adjustment.

ILME-FR7

Control block	Button/knob	Function	Conditions
Lens control block	AE button	Exposure mode selection	When the button is on (lit): Follows CONFIG >RM SETUP >AE CONFIG setting in the RM menu. When the button is off (not lit): Manual.
	FOCUS adjustment knob	Manual focus adjustment	-
	AF/MF button	Focus adjustment mode selection	-
	Push AF/MF button	Temporary focus adjustment mode change	When the AF/MF button is on (lit): Auto focus stops while the button is pressed. When the AF/MF button is off (not lit): Auto focus operates while the button is pressed.
	ND FILTER/IRIS knob	Iris value or ND filter value adjustment	Iris value adjustment when CONFIG >SW ASSIGN >IRIS KNOB is set to IRIS in the RM menu. ND filter value adjustment when set to ND FILTER.

Control block	Button/knob	Function	Conditions
Color adjustment block	WB SET button	One-push white balance auto adjustment	Enabled when OPERATION >WHITE >WB MODE is set to MEM.A T/T or MEM.A R/B in the RM menu.
	REC START/STOP button	Start/stop recording.	When the button is off (not lit): Start recording. When the button is on (lit): Stop recording.
	BARS button	Toggle color bars output on/off.	–
	ASSIGN 1 to ASSIGN 3 buttons	Toggle backlight compensation on/off.	Enabled when the AE button is lit.
		Camera assignable buttons 1 to 9	–
		FOCUS HOLD lens assignable button	–
		Display switch	–
Color temperature/R-WHITE knob and tint/B-WHITE knob	Color temperature and tint adjustment R gain and B gain adjustment	When OPERATION >WHITE >WB MODE is set to MEM-A T/T or ATW in the RM menu, color temperature and tint adjustment is enabled. When set to MEM-A R/B, R gain and B gain adjustment is enabled. When set to PRESET, color temperature adjustment only is enabled. Tint cannot be adjusted.	
Color adjustment block	R-BLACK knob/B-BLACK knob	R black and B black adjustment	Enabled when [Project] menu > [Base Setting] > [Shooting Mode] is set to [Custom] on the ILME-FR7.
	MASTER BLACK knob	Master black adjustment	–
FUNCTION menu of menu control block	ASSIGN 4 to ASSIGN 6 buttons	DETAIL LEVEL display	–
		Adjustment using VALUE knob after DETAIL LEVEL is displayed	Enabled when DETAIL is set to ON in the camera menu.
		KNEE POINT display	–
		Adjustment using VALUE knob after KNEE POINT is displayed	Enabled when both KNEE is set to ON and KNEE MODE is set to MANUAL in the camera menu.
		Direct menu AE Mode/Level shortcut button	Enabled on the shooting screen. Operated using the VALUE knob.
		Direct menu ND filter shortcut button	Enabled on the shooting screen. Operated using the VALUE knob.
		Audio input level setting	–
		Camera assignable buttons 1 to 9	–
		FOCUS HOLD lens assignable button	–
	IRIS button	Direct menu IRIS shortcut button	Enabled on the shooting screen. Operated using the VALUE knob.
	ISO/GAIN button	Direct menu ISO/Gain/EI shortcut button	Enabled on the shooting screen. Operated using the VALUE knob.
	SHUTTER button	Direct menu Shutter shortcut button	Enabled on the shooting screen. Operated using the VALUE knob.

RM Menu List

Menu item	Sub menu item	Setup item	See
OPERATION page 68	EXPOSURE	EX-COMP	page 68
		AE LEVEL	page 68
		ND FILTER	page 69
	WHITE	WB MODE	page 69
		R. WHITE	page 69
		B. WHITE	page 69
		OFFSET	page 69
	BLACK	ABB MODE	page 69
		R. BLACK	page 69
		B. BLACK	page 69
		M. BLACK	page 69
	DETAIL	SETTING	page 69
		LEVEL	page 69
	KNEE	SETTING	page 70
		KNEE MODE	page 70
		POINT	page 70
		SLOPE	page 70
	MATRIX	MATRIX	page 70
		SELECT	page 70
	OTHER	PRST SPEED	page 70
		CIZ	page 70
TELE CONV		page 70	
CONFIG page 73	RM SETUP	AE CONFIG	page 73
		AE CONFIG2	page 73
		CAM POWER	page 74
		ZOOM	page 74
		CAMERA FREQ	page 74
		LCD BRIGHT	page 74
		LAMP DIMMER	page 74
	SW ASSIGN	ASSIGN1 to 6	page 51
		IRIS KNOB	page 51
	DIRECTION	JOYSTICK PAN	page 74
		JOYSTICK TILT	page 74
		ZOOM LEVER	page 74
		FOCUS DIAL	page 75
	GPI I/O	SETTING	page 75
		TALLY MODE	page 75
		COMMAND SEL	page 75
		CAMERA LINK	page 75
	LAN		page 76
	SERIAL		page 76
	CONTROL I/F		page 76
AUTO IP SETUP page 76	SETUP IP		page 76
	ASSIGN CAM		page 76
	CLEAR TABLE		page 76
	SWAP CAM		page 76
	MANUAL		page 76
CAMERA TABLE		page 77	
MAINTENANCE page 77	MODEL INFO	MODEL	page 77
		S/NO	page 77
		VERSION	page 77
	UPDATE MODE		page 77
	RESET		page 78
	JOYSTICK	SENSITIVITY	page 78

OPERATION

You can check and change camera menu settings while operating a camera. This menu is also used to set and change the speed of movement between positions when using the preset memory function.

During operation, the settings of the OPERATION menu setup items display the settings configured on the camera.

Accordingly, default settings are not indicated in the description of each setting.

To store the settings changed using this menu, use the preset memory function of the camera.

For details about items saved with a preset number, refer to the operating instructions of each camera.

Notes

- Items that cannot be set on the selected camera display "---" as the setting.
- Depending on the camera model, the settings displayed on the unit and camera menu display may not be the same. In this case, the settings displayed in the camera menu are the actual settings.
- When changing a setting, there may be some delay before the display is updated.

```
< OPERATION >
→ EXPOSURE
  WHITE
  BLACK
  DEATIL
  KNEE
  MATRIX
  PRESET
  OTHER
PRST : TRACE
```

EXPOSURE

Sets the exposure compensation function of the target camera.

EX-COMP

Turns the exposure compensation mode on/off.

AE LEVEL

Sets the control level for automatic camera brightness control (exposure compensation level).

ND FILTER

Changes the ND filter in the camera according to the brightness of the subject being shot. The reduction in light level using the ND filter increases with increasing ND filter number (ND2 to ND4). Setting to ND1 turns the ND filter off.

WHITE

Sets the white balance adjustment function of the target camera.

WB MODE

For BRC-X1000/H800/H780/X400/X401, BRC-H900, SRG series ^{*1} target cameras

Settings	Description
AUTO1_AWB	Automatically adjusts the white balance using AUTO1.
AUTO2_ATW	Automatically adjusts the white balance using AUTO2. ^{*2}
INDOOR	Adjusts to a white balance suitable for indoor shooting.
OUTDOOR	Adjusts to a white balance suitable for outdoor shooting.
ONE PUSH	Executes a white balance adjustment. Shoot a large white object in the center of the screen and press the O.P.AWB button.
MANUAL	Adjusts the white balance manually. Selecting this enables the R. WHITE and B. WHITE items.
SODIUM	Adjusts to a white balance suitable for shooting under high-pressure sodium lamps. ^{*3}

^{*1} Target cameras: SRG-360SHE/280SHE, SRG-300SE/301SE/201SE, SRG-300H/301H, SRG-120DH/121DH/120DS/120DU/HD1, SRG-X400/201M2, SRG-X120/HD1M2, SRG-XB25, SRG-XP1

^{*2} For SRG series target cameras, the ATW white balance mode on the camera is applied.

^{*3} Target cameras: SRG-XB25, SRG-XP1

For an ILME-FR7 target camera

Settings	Description
ATW	Adjusts the white balance using auto tracking. You can also force adjustment using the WB SET button of the unit.
MEM.A T/T	Adjusts the white balance by adjusting the color temperature and tint. You can also run auto adjustment using the WB SET button in the same way as ONE PUSH.
MEM.A R/B	Adjusts the white balance by adjusting R.WHITE and B.WHITE. You can also run auto adjustment using the WB SET button in the same way as ONE PUSH.
PRESET	Adjusts the white balance by adjusting the color temperature in 100K increments.

R. WHITE

Sets the R. WHITE value.

B. WHITE

Sets the B. WHITE value.

OFFSET

Adjusts the offset level of the white convergence point. Negative values shift the convergence point in the blue direction, and positive values shift the convergence point in the red direction.

BLACK

Sets the black balance adjustment function of the target camera.

ABB MODE

Turns the black balance adjustment function on/off.

R. BLACK

Sets the R. BLACK value.

B. BLACK

Sets the B. BLACK value.

M. BLACK

Sets the M. BLACK value.

DETAIL

Sets the detail enhancement function of the target camera.

SETTING

Turns the detail correction function on/off. When set to ON, you can set the level of detail correction.

LEVEL

Adjusts the level of detail correction.

KNEE

Sets the KNEE correction function on the target camera.

SETTING

Turns the KNEE correction function on/off. When set to ON, the high luminance parts of the image are compressed.

KNEE MODE

Settings	Description
AUTO	Automatically calculates the optimum luminance level at which knee correction is applied from the luminance level of the image being shot.
MANUAL	Allows you to adjust the luminance level at which knee correction (POINT and SLOPE) is applied, irrespective of the luminance level of the image being shot.

POINT

Adjusts KNEE POINT.

SLOPE

Adjusts the gradient of the slope above the knee point (degree of compression).

MATRIX

Sets the MATRIX adjustment function on the target camera.

MATRIX

Turns the MATRIX adjustment function on/off. When set to ON, you can enhance or weaken a specific color region while keeping the white convergence point unchanged.

SELECT

Selects a built-in preset matrix used for matrix calculation. You can choose from STD, HIGH SAT, and FL LIGHT.

OTHER

Sets the speed of movement when switching positions using preset memory. Used to make other settings on the target camera.

PRST SPEED

Sets the speed of movement when switching positions using preset memory. For an ILME-FR7 target camera, a value that is double the value selected here is applied when the Speed Step setting for pan/tilt is set to Extended on the camera.

CIZ

Turns the Clear Image Zoom function of the target camera on/off.

TELE CONV

Magnifies the image two times using the teleconverter function of the target camera.

Settings	Description
OFF	Magnification function is not used.
ON	Magnification function is used.

OPERATION menu support by camera model

Yes: Supported
 -: Not supported

Setup item		Function	Conditions	BRC-X1000/ H800/H780/ X400/X401	BRC- H900	SRG series 1*	ILME- FR7
EXPOSURE	EX-COMP	Exposure compensation function on/off	-	Yes	Yes ^{*2}	Yes	-
	AE LEVEL	Exposure compensation level setting	Enabled when EX-COMP is set to ON.	Yes	Yes	Yes	-
	ND FILTER	ND filter function on/off	-	Yes ^{*3}	-	-	-
WHITE	WB MODE	White balance adjustment method selection ^{*4}	-	Yes	Yes	Yes	Yes
	R. WHITE	R. WHITE value setting	Enabled when WB MODE is set to MANUAL.	Yes	Yes	Yes	Yes
	B. WHITE	B. WHITE value setting	Enabled when WB MODE is set to MANUAL.	Yes	Yes	Yes	Yes
	OFFSET	Convergence point offset adjustment	Enabled when WB MODE is set to AUTO1, AUTO2, or ONE PUSH.	Yes	Yes	Yes ^{*5}	-
BLACK	ABB MODE	Black balance adjustment function setting	-	-	Yes	-	-
	R. BLACK	R. BLACK value setting	-	-	Yes	-	Yes
	B. BLACK	B. BLACK value setting	-	-	Yes	-	Yes
	M. BLACK	M. BLACK value setting	-	Yes	-	-	Yes
DETAIL	SETTING	Detail correction function on/off	-	Yes ^{*2}	Yes	Yes ^{*2}	Yes
	LEVEL	Detail correction level setting	Enabled when SETTING is set to ON.	Yes	Yes	Yes ^{*6}	Yes
KNEE	SETTING	KNEE correction function on/off	-	Yes	Yes	-	Yes
	KNEE MODE	KNEE adjustment function AUTO/MANUAL selection	Enabled when SETTING is set to ON.	Yes	Yes	-	Yes
	POINT	KNEE POINT setting	Enabled when KNEE MODE is set to MANUAL.	Yes	Yes	-	Yes
	SLOPE	KNEE slope setting	Enabled when KNEE MODE is set to MANUAL.	Yes	Yes	-	Yes
MATRIX	MATRIX	MATRIX adjustment function on/off	-	Yes	Yes	-	-
	SELECT	Built-in preset matrix selection used for matrix calculation	Enabled when MATRIX is set to ON.	Yes	Yes	-	-
OTHER	PRST SPEED	Speed of movement setting when switching positions using the preset memory function.	-	Yes	Yes	Yes ^{*5}	Yes
	CIZ	Clear Image Zoom on/off	-	Yes	Yes	Yes ^{*7}	-
	TELE CONV	Teleconverter function on/off	-	Yes	Yes	Yes ^{*8}	-

- *1 Target cameras: SRG-360SHE/280SHE, SRG-300SE/301SE/201SE, SRG-300H/301H, SRG-120DH/121DH/120DS/120DU/HD1, SRG-X400/201M2, SRG-X120/HD1M2, SRG-A40/A12, SRG-XB25, SRG-XP1
- *2 Always set to ON. Cannot be set to OFF.
- *3 Supported in firmware version 2.0 or later on the BRC-X1000, BRC-H800, and BRC-H780.
- *4 The supported WB MODE varies depending on the camera model. For details, see "WHITE" (page 69).
- *5 SRG-X400/201M2, SRG-X120/HD1M2, and SRG-A40/A12 only
- *6 Except for SRG-X400/201M2, SRG-X120/HD1M2, SRG-A40/A12, SRG-XB25, and SRG-XP1, the APERTURE setting of the PICTURE menu on the camera is applied.
- *7 SRG-X400/201M2, SRG-A40 only (SRG-XB25/XP1 support PIXEL ZOOM on/off switching)
- *8 SRG-A40/A12 only

CONFIG

This menu is used to configure functions of the unit.

```
<CONFIG>
→RM SETUP
 SW ASSIGN
 DIRECTION
 GPI I/O
 LAN
 SERIAL
 CONTROL I/F: LAN
 PRST:TRACE
```

RM SETUP

Sets the operation of the unit.

AE CONFIG

For a target camera other than an ILME-FR7, this sets the brightness adjustment method. You can select the following exposure modes when the AE button on the lens control block is off. To apply the setting, after selection, turn the AE button on and then off again.

Settings (Bold: default value)	Description
MANUAL	The gain (GAIN), electronic shutter speed (SPEED), and iris (IRIS) can be adjusted manually.
SHUT Pri	Automatically adjusts the exposure using the gain and iris. Adjust the electronic shutter speed (SPEED) manually.
IRIS Pri	Automatically adjusts the exposure using the gain and electronic shutter speed. Adjust the iris (IRIS) manually.
GAIN Pri	Automatically adjusts the exposure using the electronic shutter speed (SPEED) and iris (IRIS). Adjust the gain (GAIN) manually.

AE CONFIG2

For an ILME-FR7 target camera, this sets the brightness adjustment method. You can select the following exposure modes when the AE button on the lens control block is on. To apply the setting, after selection, turn the AE button off and then on again. Note that if the ND filter is set to CLEAR, the auto ND filter function does not operate.

Settings (Bold: default value)	Description
ALL	Automatically adjusts the exposure using the ND filter, iris, gain, and electronic shutter speed.
ND+I+G	Automatically adjusts the exposure using the ND filter, iris, and gain. Adjust the electronic shutter speed manually.
ND+I+S	Automatically adjusts the exposure using the ND filter, iris, and electronic shutter speed. Adjust the gain manually.
ND+IRIS	Automatically adjusts the exposure using the ND filter and iris. Adjust the gain and electronic shutter speed manually.
ND+G+S	Automatically adjusts the exposure using the ND filter, gain, and electronic shutter speed. Adjust the iris manually.
ND+GAIN	Automatically adjusts the exposure using the ND filter and gain. Adjust the iris and electronic shutter speed manually.
ND+SHT	Automatically adjusts the exposure using the ND filter and electronic shutter speed. Adjust the iris and gain manually.
ND	Automatically adjusts the exposure using the ND filter. Adjust the iris, gain, and electronic shutter speed manually.
I+G+S	Automatically adjusts the exposure using the iris, gain, and electronic shutter speed. Adjust the ND filter manually.
IRIS+GAIN	Automatically adjusts the exposure using the iris and gain. Adjust the ND filter and electronic shutter speed manually.
IRIS+SHT	Automatically adjusts the exposure using the iris and electronic shutter speed. Adjust the ND filter and gain manually.
IRIS	Automatically adjusts the exposure using the iris. Adjust the ND filter, gain, and electronic shutter speed manually.
GAIN+SHT	Automatically adjusts the exposure using the gain and electronic shutter speed. Adjust the ND filter and iris manually.
GAIN	Automatically adjusts the exposure using the gain. Adjust the ND filter, iris, and electronic shutter speed manually.

Settings (Bold: default value)	Description
SHT	Automatically adjusts the exposure using the electronic shutter speed. Adjust the ND filter, iris, and gain manually.

CAM POWER

Settings (Bold: default value)	Description
EACH	Only the target camera turns on/off when using the CAM POWER button.
ALL	All cameras registered in the camera table turn on/off when using the CAM POWER button.

Note

SRG-300SE, SRG-301SE, and SRG-201SE do not switch to standby mode.

ZOOM

Settings (Bold: default value)	Description
LEVER	Controls the zoom of the target camera using the ZOOM lever on the lens control block.
JOYSTICK	Controls the zoom of the target camera using the ZOOM ring on the joystick.
BOTH	Controls the zoom of the target camera using both the ZOOM lever and the ZOOM ring on the joystick.

CAMERA FREQ

Settings (Bold: default value)	Description
59.94 , 50, 23.98	Selects the frame rate for the shutter speed displayed in the menu. You can select from 59.94 [Hz], 50 [Hz], and 23.98 [Hz].*

* The shutter speed is displayed in the status display (page 62).

LCD BRIGHT

Adjusts the brightness of the LCD panel in five increments, 1 (dark) to 5 (bright).

LAMP DIMMER

Adjusts the brightness of the LED buttons in five increments, 1 (dark) to 5 (bright).

SW ASSIGN

ASSIGN 1 to ASSIGN 6

Assign functions to the ASSIGN 1 to ASSIGN 6 buttons of the unit.

IRIS KNOB

If the target camera is equipped with a variable ND filter, you can assign a function to the IRIS knob.

For details about function assignments to assign buttons, see "Assigning Functions to Assign Buttons" (page 51).

DIRECTION

Sets the control direction of the joystick, ZOOM lever, and FOCUS knob.

JOYSTICK PAN

Settings (Bold: default value)	Description
STANDARD	Inclining the joystick to the right pans the camera to the right. Inclining to the left pans the camera to the left.
REVERSE	Inclining the joystick to the right pans the camera to the left. Inclining to the left pans the camera to the right.

JOYSTICK TILT

Settings (Bold: default value)	Description
STANDARD	Inclining the joystick forward tilts the camera up. Inclining rearward tilts the camera down.
REVERSE	Inclining the joystick forward tilts the camera down. Inclining rearward tilts the camera up.

ZOOM LEVER

Settings (Bold: default value)	Description
STANDARD	Moving the ZOOM lever to the W side (Wide) zooms out, and moving to the T side (Tele) zooms in.
REVERSE	Moving the ZOOM lever to the W side (Wide) zooms in, and moving to the T side (Tele) zooms out.

FOCUS DIAL

Settings (Bold: default value)	Description
STANDARD	Turning the FOCUS knob clockwise moves the focus in the Far direction, and turning counterclockwise moves the focus in the Near direction.
REVERSE	Turning the FOCUS knob clockwise moves the focus in the Near direction, and turning counterclockwise moves the focus in the Far direction.

GPI I/O

Sets the GPI I/O connector signal format and tally operation mode.

SETTING

Settings (Bold: default value)	Description
INPUT	Sets the control signal direction of the GPI I/O connector to INPUT. In this case, connect a tally control input signal to the connector.
OUTPUT	Sets the control signal direction of the GPI I/O connector to OUTPUT. In this case, the connector functions as a contact output connector which outputs the camera number of the target camera.

TALLY MODE

This setting is enabled when SETTING is set to INPUT.

Settings (Bold: default value)	Description
NORMAL	Displays the tally input lamp corresponding to the number of the camera with tally input ON, and automatically selects the camera as the target camera.
ON AIR	Displays the tally input lamp corresponding to the number of the camera with tally input ON.

COMMAND SEL

Settings (Bold: default value)	Description
STANDARD	Sets the input/output method to STANDARD method. The camera numbers and input/output pin numbers have a 1:1 correspondence. <ul style="list-style-type: none"> If the unit and cameras are connected by serial connection, cameras 1 to 7 correspond to input/outputs 1 to 7. If the unit and cameras are connected by LAN connection, cameras 1 to 10 in group 1 correspond to input/outputs 1 to 10.
EXPAND	Handles camera numbers as binary numbers. <ul style="list-style-type: none"> Tally input numbers 8 and higher in a serial connection are ignored. In this case, the response is equivalent to no input. Numbers in a LAN connection, corresponding to cameras 1 to 10 in groups 1 to 10, are handled as the numbers 1 to 100. Tally input numbers 101 and higher are ignored. In this case, the response is equivalent to no input.

CAMERA LINK

Settings (Bold: default value)	Description
ON, OFF	Turns tally lamp control on/off. The tally lamp control operation varies depending on the combination of the SETTING and CAMERA LINK settings. For details, see "Tally lamp control operation" below.

Tally lamp control operation

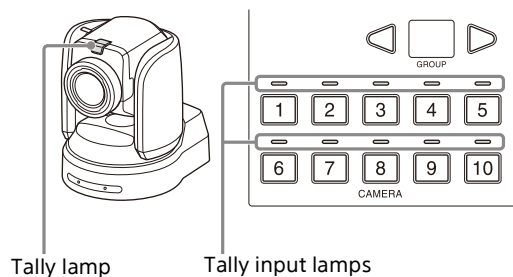

CAMERA LINK setting	Control lamps	SETTING setting	
		IN	OUT
OFF	Tally input lamps 1 to 10	Displays the tally input lamp corresponding to the number of the camera with tally input ON.	Not lit
	Camera tally lamp	The camera tally lamps are not controlled. A tally lamp ON/OFF command is not sent.	
ON	Tally input lamps 1 to 10	Displays the tally input lamp corresponding to the number of the camera with tally input ON.	Not lit
	Camera tally lamp	Displays the camera tally lamp corresponding to the number of the camera with tally input ON.	The tally lamp of the target camera becomes the control target, and the camera tally lamp lights up.

LAN

Configures the network of the unit when the unit and target cameras are connected by LAN connection.
For details, see "Setting the IP address of the unit" (page 15).

SERIAL

Configures serial connections when the unit and target cameras are connected by serial connection.
For details, see "Configuring a serial connection" (page 25).

CONTROL I/F

Displays the enabled control interface of cameras.
When LAN connection is enabled, LAN is displayed. When serial connection is enabled, SERIAL is displayed.

AUTO IP SETUP

This menu is used to configure the automatic assignment of IP addresses of the detected cameras on the network.
This is used when the unit and cameras are connected by LAN connection.

```

<AUTO IP SETUP>
>SETUP IP
  ASSIGN CAM
  CLEAR TABLE
  SWAP CAM
  MANUAL
  CAMERA TABLE

PRST:TRACE

```

SETUP IP

Assigns IP addresses to cameras automatically, and then assign the cameras to the camera selection buttons of the unit.
For details, see "Assignment using AUTO IP SETUP >SETUP IP" (page 18).

ASSIGN CAM

Assigns cameras that already have configured IP addresses to the camera selection buttons of the unit.
For details, see "Assignment using AUTO IP SETUP >ASSIGN CAM" (page 19).

CLEAR TABLE

Clears the camera information.
For details, see "To clear the camera table" (page 20).

SWAP CAM

Swaps the camera number and camera information of two cameras registered in the camera table.
For details, see "To swap camera numbers" (page 20).

MANUAL

Used to change the group number, camera number, and IP address assigned to a camera or clear the camera registration manually.
For details, see "Changing the camera registration and settings manually" (page 21).

CAMERA TABLE

Displays the camera information (IP address and MAC address) registered in the camera table. For details, see "To check the camera table" (page 21).

MAINTENANCE

This menu is used to perform maintenance of the unit.

```
< MAINTENANCE >
→ MODEL INFO
  UPDATE MODE
  RESET

PRST : TRACE
```

MODEL INFO

Displays model information about the unit.

MODEL

Display	Description
RM-IP500	Displays the model name of the unit.

S/NO

Display	Description
1234567	Displays the serial number of the unit.

VERSION

Display	Description
X.XX	Displays the firmware version of the unit.

UPDATE MODE

To permit access to the unit from a PC, set UPDATE MODE to ON. Enable update mode when backing up or restoring settings, or using the setup software RM-IP Setup Tool.

When UPDATE MODE is set to ON, all operations are disabled, except the VALUE knob and VALUE button operation.

To return to normal operation mode, set UPDATE MODE to OFF.

For details, see "Using a Setup PC" (page 28).

Note

When UPDATE MODE is set to ON, the buttons on the control panel blink at roughly 1-second intervals. Blinking indicates that external access to the unit is permitted. It does not indicate a malfunction.

RESET

Resets all settings stored on the unit to their default values.

For details, see "Restoring Factory Default Settings" (page 62).

SENSITIVITY

Sets the operational sensitivity of the joystick for pan/tilt.

Settings (Bold: default value)	Description
1, 2, 3, 4, 5	The higher the number, the higher the sensitivity.

Troubleshooting

Before bringing in your unit for service, check the following as a guide to troubleshoot the problem. If the problem cannot be corrected, consult with your Sony dealer.

Symptom	Cause	Remedy
The power of the unit is not turned on.	The AC power adapter is not connected to the DC power input connector firmly.	Insert the power cord firmly as far as it will go.
	The AC power cord is not inserted firmly into the AC power adapter or the AC outlet.	Insert the power cord firmly as far as it will go.
The camera cannot be operated with the unit.	The physical connection and communication method settings are different.	<p>Check the communication method (LAN or SERIAL) in CONFIG >CONTROL I/F in the RM menu.</p> <p>Change the communication method setting if it is different to the physical connection method.</p> <ul style="list-style-type: none"> • "VISCA over IP (LAN) connection" (page 15) • "Configuring a serial connection" (page 25) <p>Note</p> <p>LAN connection and serial connection cannot be used at the same time.</p>
	(Serial connection) The communication baud rate setting of the camera and the unit differ.	Set the baud rate to the same setting as the camera (9,600 bps or 38,400 bps) (page 25).
	(Serial connection) The VISCA RS-422 connection is not correctly made.	Check the connection of the VISCA RS-422 OUT connector and the RS-422 cable (page 23 and 24).
	(LAN connection) The GROUP number differs.	Select the correct GROUP number of the target camera (page 34).
	(LAN connection) There is a mismatch between the MAC address and IP address information of the connected camera and the registered camera table.	Delete the camera table contents using AUTO IP SETUP >CLEAR TABLE in the RM menu, and build the camera table again (page 20).
	A menu other than the FUNCTION menu, OPERATION menu, RM menu, or top menu is displayed.	Select the RM menu top menu.
	(For an ILME-FR7 target camera) VISCA over IP communication on the camera is disabled.	Refer to the Help Guide of the camera and enable VISCA over IP communication.
	Operation is not possible while the control panel buttons and LEDs are blinking.	The remote controller is set to update mode.
The group number is not displayed, and the GROUP LEFT and GROUP RIGHT buttons cannot be operated. CAMERA 8 to 10 buttons cannot be selected.	Not using a LAN connection.	These functions are enabled for a LAN connection only.

Messages Displayed on the LCD Panel

In addition to the setup items and status display on the LCD panel, warning messages indicating that an operation was not executed and error messages indicating that an operation was not successful are also displayed.

The following table describes the meaning and remedy for typical messages.

Warning messages

Message	Meaning	Cause and remedy
*** CAMERAS WILL REMAIN UNREGISTERED	The number of cameras registered successfully is smaller than the number of detected cameras. "****" indicates the number of cameras that could not be registered.	This message may be displayed when making camera assignments using AUTO IP SETUP > SETUP IP or AUTO IP SETUP > ASSIGN CAM. <ul style="list-style-type: none">The camera IP addresses are outside the range set by the start address in [FROM] and the end address in [TO]. Reconfigure the start address in [FROM] and the end address in [TO].The number of cameras that can be registered in the camera table exceeds the maximum number. Re-select the cameras to register.
NO CAMERA WAS FOUND	No cameras were detected.	This message may be displayed when making camera assignments using AUTO IP SETUP > SETUP IP or AUTO IP SETUP > ASSIGN CAM. <ul style="list-style-type: none">Reconfigure the start address in [FROM] and the end address in [TO].Check the connection status of the unit and cameras, and the camera power supply status.Connect the unit and cameras using the VISCA over IP (LAN) connection method. (For an ILME-FR7 target camera) Restart the camera. To change the IP address using AUTO IP SETUP, do so within 20 minutes of starting the camera.
ALL CAMERAS HAVE BEEN REGISTERED	All of the detected cameras have been registered.	This message may be displayed when making camera assignments using AUTO IP SETUP > SETUP IP or AUTO IP SETUP > ASSIGN CAM. All of the detected cameras are registered. Re-select the cameras to register.
CAMERA TABLE WAS NOT CHANGED	The camera table has not been changed.	

Error messages

Message	Meaning	Cause and remedy
DUPLICATE IP ADDRESS PLEASE CHANGE IP ADDR	There are devices with duplicate IP addresses on the network.	This message is displayed when the network connection settings are checked. Specify different IP addresses.
INVALID IP ADDRESS PLEASE CHANGE IP ADDR	There is a device configured with an IP address that cannot be used on the network.	This message is displayed when the network connection settings are checked. Change the IP address of the device.
INVALID SUBNET MASK PLEASE CHANGE SM	There is a device configured with a subnet mask that cannot be used on the network.	This message is displayed when the network connection settings are checked. Change the subnet mask setting of the device.

Message	Meaning	Cause and remedy
INVALID GW ADDRESS PLEASE CHANGE GW ADDR	There is a device configured with a default gateway that cannot be used on the network.	This message is displayed when the network connection settings are checked. Change the default gateway setting of the device.
DETECTED SAME MAC ADD BUT DIFFERENT IP ADD	The MAC address of a detected camera is the same as a registered camera, but the IP address of the camera and the address in the camera table are different.	This message may be displayed when making camera assignments using AUTO IP SETUP >ASSIGN CAM. Change the settings so that the IP address of the camera matches the IP address in the camera table.
INVALID IP ADDRESS PLEASE CHANGE IP ADDR	A camera configured with the same IP address as the unit was detected.	This message may be displayed when making camera assignments using AUTO IP SETUP >SETUP IP. Change the IP address of the camera or the unit so that they are different.
DUPLICATE IP ADDRESS DETECTED IN NETWORK	Duplicate IP address settings were detected.	This message may be displayed when making camera assignments using AUTO IP SETUP >ASSIGN CAM. There are devices with the same IP addresses on the network. Configure the IP addresses so that they are different.
SAME IP ADDRESS ALREADY IN CAM TABLE	The IP address of the detected camera is already registered in the camera table.	This message may be displayed when making camera assignments using AUTO IP SETUP >ASSIGN CAM. The IP address of the detected camera is the same as the IP address of a camera registered in the camera table. Change either one of the IP addresses.
DIFFERENT IP NETWORK SET SAME SEGMENT	The segment of the IP address of the detected camera is different from the segment of the unit.	This message may be displayed when making camera assignments using AUTO IP SETUP >ASSIGN CAM. A camera cannot be recognized if the segment of the IP address of the unit is different. Set the segment of the IP address of the camera to the same segment as the IP address of the unit.
ALREADY REGISTRATION IN THIS GP/CAM	A camera is already assigned to the target GROUP and CAMERA buttons.	This message may be displayed when changing camera assignments for the GROUP and CAMERA buttons. A camera is already assigned to the target GROUP and CAMERA buttons. Assign to different GROUP and CAMERA buttons.
DUPLICATE IP ADDRESS ON THE CAMERA TABLE	An attempt was made to change an IP address to an IP address that is registered in the camera table.	This message may be displayed when changing the IP address of a camera. Use different IP addresses.
DUPLICATE IP ADDRESS IN THE NETWORK	An attempt was made to change an IP address to an IP address that is used by a device on the network.	This message may be displayed when changing the IP address of a camera. Use different IP addresses.
CAMERA BUSY	The camera could not accept the change in settings.	This message may be displayed when changing the IP address of a camera. The camera is busy and cannot accept the change in settings.
NO RESPONSE	There was no response from the cameras.	This message may be displayed when changing the IP address of a camera. There are no cameras on the network or the cameras are not responding.

Specifications

Input/output connectors

Control input/output

VISCA RS-422 OUT connector:
RJ-45

LAN connector: RJ-45, 10BASE-T/
100BASE-TX auto sensing

GPI I/O: D-sub 15-pin TALLY IN/
CONTACT OUT

Control signal format (RS-422 communication)
9,600 bps/38,400 bps

Power connector

JEITA type 4 (12 V DC)

General specifications

Input voltage 12 V DC (10.8 V to 13.2 V)

Current consumption

0.6 A max. (All lamps lit)

Operating temperature

0 °C to 40 °C (32 °F to 104 °F)

Storage temperature

-20 °C to +60 °C (-4 °F to +140 °F)

Dimensions 306 mm × 159.3 mm × 224.1 mm

(12 1/8 in × 6 3/8 in × 8 7/8 in)

(width / height / depth)

(excluding protrusions)

Mass Approximately 2400 g (5 lb 4.7 oz)

Optional accessories

AC adapter (AC-UES1230 series)

For details about the recommended AC adapter,
contact your Sony sales representative.

Design and specifications are subject to change
without notice.

Dimensions

Top

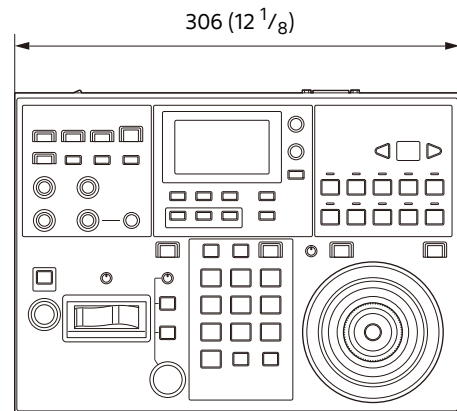

Unit: mm (in)

Front

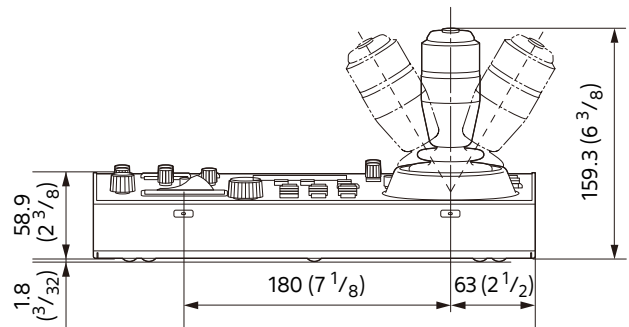

Unit: mm (in)

Side

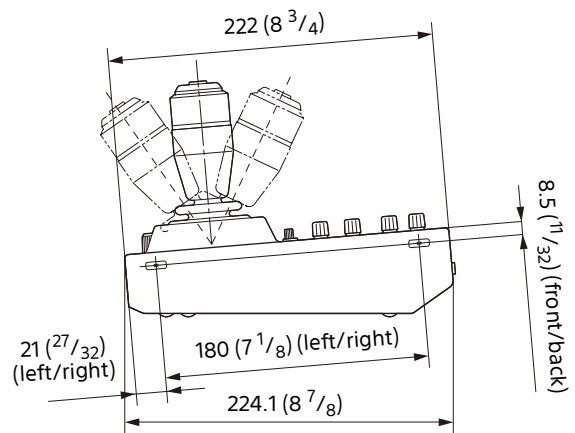

Unit: mm (in)

Rear

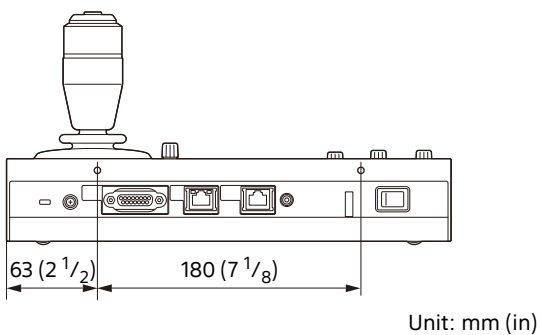

Pin assignments

VISCA RS-422 OUT connector



Pin	Signal name
1	RXD OUT-
2	RXD OUT+
3	TXD OUT-
4	GND
5	GND
6	TXD OUT+
7	No connection
8	No connection

GPI I/O connector (D-sub 15-pin, female)

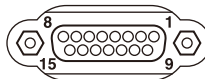

Pin	Signal name
1	TALLY IN/CONTACT OUT 1
2	TALLY IN/CONTACT OUT 2
3	TALLY IN/CONTACT OUT 3
4	TALLY IN/CONTACT OUT 4
5	TALLY IN/CONTACT OUT 5
6	TALLY IN/CONTACT OUT 6
7	TALLY IN/CONTACT OUT 7
8	TALLY IN/CONTACT OUT 8
9	TALLY IN/CONTACT OUT 9
10	TALLY IN/CONTACT OUT 10
11	No connection
12	No connection
13	GND
14	GND
15	GND

TALLY/CONTACT connector input connection example

Switch or relay connection

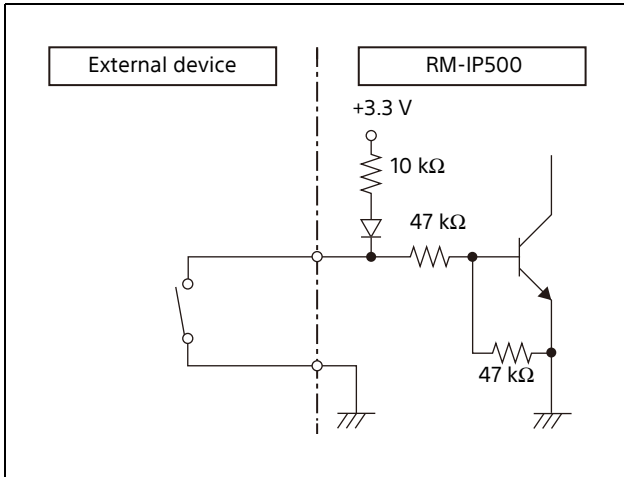

Open-collector connection

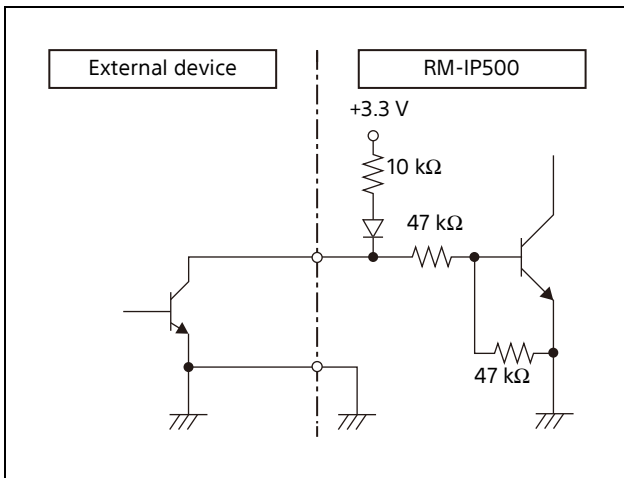

TALLY/CONTACT connector output connection example

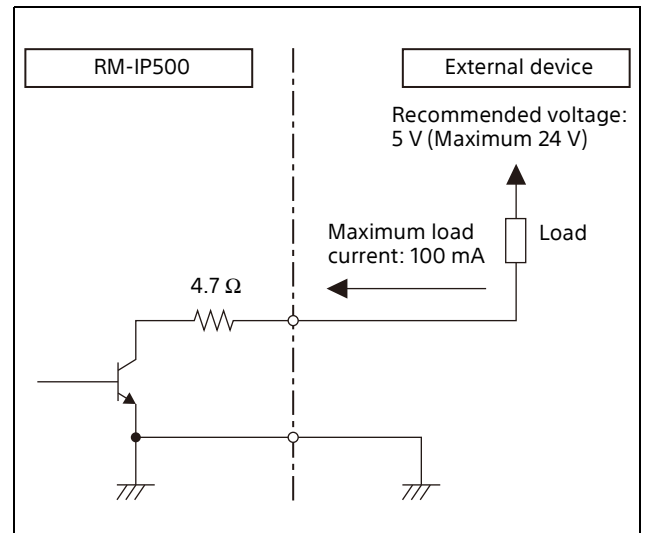

Input waveform of TALLY/CONTACT connector

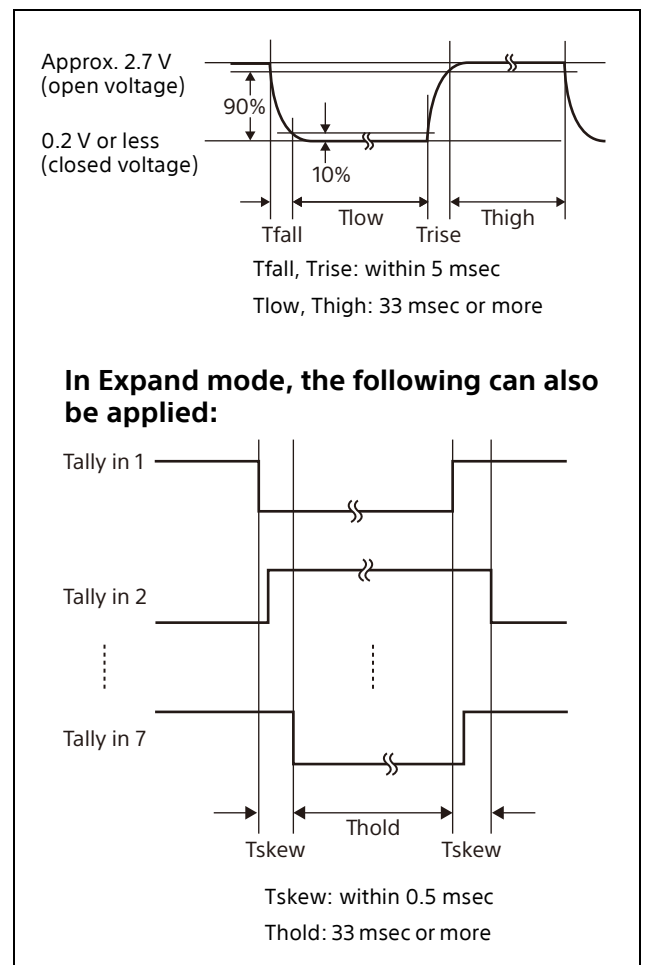

License

uIP

This software partially supports component uIP. Therefore the following license conditions apply.

Copyright (c) 2001-2006, Adam Dunkels and the Swedish Institute of Computer Science All rights reserved.

Redistribution and use in source and binary forms, with or without modification, are permitted provided that the following conditions are met:

- 1) Redistributions of source code must retain the above copyright notice, this list of conditions and the following disclaimer.
- 2) Redistributions in binary form must reproduce the above copyright notice, this list of conditions and the following disclaimer in the documentation and/or other materials provided with the distribution.
- 3) All advertising materials mentioning features or use of this software must display the following acknowledgement:
This product includes software developed by the organization.
- 4) Neither the name of the organization nor the names of its contributors may be used to endorse or promote products derived from this software without specific prior written permission.

THIS SOFTWARE IS PROVIDED BY COPYRIGHT HOLDER "AS IS" AND ANY EXPRESS OR IMPLIED WARRANTIES, INCLUDING, BUT NOT LIMITED TO, THE IMPLIED WARRANTIES OF MERCHANTABILITY AND FITNESS FOR A PARTICULAR PURPOSE ARE DISCLAIMED. IN NO EVENT SHALL {{COPYRIGHT HOLDER}} BE LIABLE FOR ANY DIRECT, INDIRECT, INCIDENTAL, SPECIAL, EXEMPLARY, OR CONSEQUENTIAL DAMAGES (INCLUDING, BUT NOT LIMITED TO, PROCUREMENT OF SUBSTITUTE GOODS OR SERVICES; LOSS OF USE, DATA, OR PROFITS; OR BUSINESS INTERRUPTION) HOWEVER CAUSED AND ON ANY THEORY OF LIABILITY, WHETHER IN CONTRACT, STRICT LIABILITY, OR TORT (INCLUDING NEGLIGENCE OR OTHERWISE) ARISING IN ANY WAY OUT OF THE USE OF THIS SOFTWARE, EVEN IF ADVISED OF THE POSSIBILITY OF SUCH DAMAGE.

μT-Kernel2.0

This Product uses the Source Code of μT-Kernel2.0 under T-License 2.2 granted by TRON Forum (www.tron.org).

