

# Stereo VideoMic X

Professional grade Stereo on-camera microphone

**AUSTRALIA**  
107 Carnarvon st, Silverwater NSW 2128 Australia  
Ph: +61 2 9648 5855 Fx: +61 2 9648 2455

**USA**  
PO Box 91028, Long Beach CA 90809-1028  
Ph: +1 562 364 7400 Fax: +1 888 412 4664

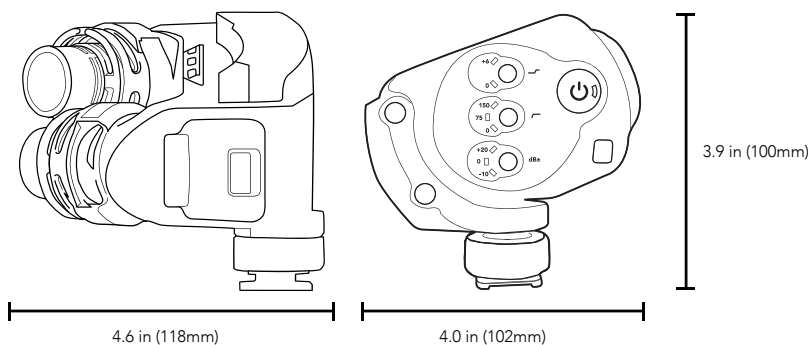

## Features

- Acoustically matched true condenser capsules
- Rycote® Lyre onboard shock mounting
- Balanced professional XLR output
- Heavy-duty, lightweight aluminium construction
- High Pass Filter
- 9V or Phantom Power (P48 - via miniXLR)
- Level adjustment
- High Frequency Boost
- Included pop shield and wind shield (not shown)
- 10 Year Warranty\*

## Specifications

Acoustic Principle	Pressure Gradient
Polar Pattern	Cardioid
Frequency Rate	40Hz ~ 20kHz
Frequency Range (High Pass Filter)	0, 75, 150Hz
Variable Level	-10, 0, +20dB
Output Impedance	200Ω
Signal to Noise Ratio	82 dBA SPL (as per IEC651)
Equivalent Noise	12 dBA SPL (as per IEC651)
Maximum SPL	143dB SPL
Sensitivity	-32 dB re 1V/Pa (25mV @ 94dB SPL) ± 2dB @ 1kHz
Dynamic Range	131 dB SPL
Power Requirements	9V alkaline battery or P48 (via miniXLR)
Output Connection (Unbalanced)	3.5 Stereo mini jack plug (dual mono), Tip – left channel, Ring – right channel
Output Connection (Balanced) †	Mini XLR (TA3F style connector) Pin 1 (Ground), Pin 2 (+), Pin 3 (-).
Battery Life	30 hours
Weight (No Battery)	300g

## Polar pattern

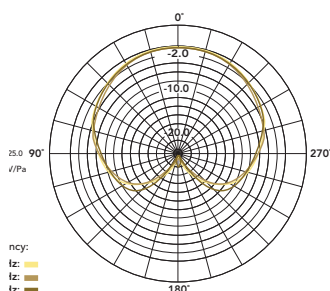

## Frequency response

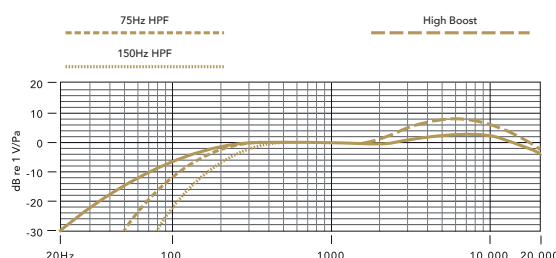

## Notes

\* Online registration is required for 10 year warranty

† Cable not included

**RØDE**  
MICROPHONES