

Nikon

NIKKOR

AF Fisheye-Nikkor 16mm f/2.8D

Sc 使用说明书

随附配件
插入式镜头前盖
镜头后盖
卡口型滤镜 (L37C、A2、B2和O56)
滤镜套 CA-2

En User's Manual
Supplied Accessories
Slip-on front lens cap
Rear lens cap
Bayonet-type filters (L37C, A2, B2, and O56)
Filter Case CA-2

NIKKON CORPORATION	Printed in Japan SB5C02(27) 7MAA4727-02
---------------------------	--

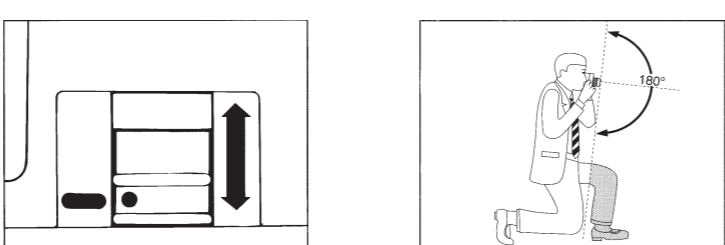
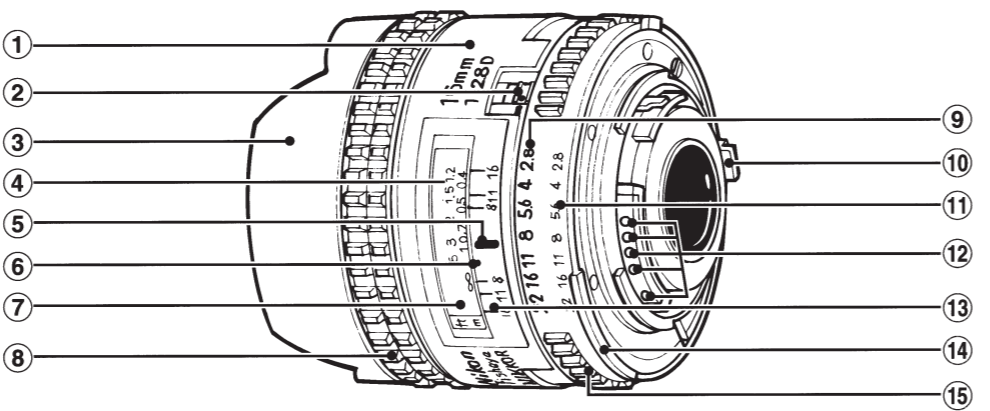

图A

图B

■ 镜头部件

- | | | |
|----------------|------------|----------|
| ① 镜头镜筒 | ⑦ 对焦距离指示窗口 | ⑬ CPU 接点 |
| ② 最小光圈锁定杆 | ⑧ 对焦环 | ⑭ 景深指示 |
| ③ 镜头遮光罩 | ⑨ 光圈刻度 | ⑮ 测光耦合符 |
| ④ 对焦距离指示 | ⑩ 光圈传递杆 | ⑯ 光圈环 |
| ⑤ 焦距/光圈/镜头安装标记 | ⑪ 光圈直读刻度 | |
| ⑥ 红外线补偿标记（白色） | | |

■ 注意事项

- 请保持 CPU 镜头接点清洁并小心不要损坏 CPU 接点。
- 不要将以下配件直接安装至本镜头 : PK-1或 PK-11自动延伸环、K1环或 BR-4自动环（PK-11A和 BR-8可分别代替PK-11和 BR-4使用）。若不遵守此注意事项，可能会导致损坏本镜头的 CPU 接点或其他部件。其他镜头配件可能与照相机不兼容；请务必在使用前先查阅照相机的说明书。
- 本镜头无法与用于尼康 F3AF照相机的 DX-1取景器一起使用。

■ 对焦

自动对焦适用于尼康自动对焦照相机；若要手动对焦，请旋转对焦环直至取景器中的图像清楚鲜明。

■ 对焦屏

“对焦屏”表格中所列照相机支持用于不同镜头或不同情况下的多种对焦屏。表格中所列对焦屏均适用于本镜头。

当将 B2/B3、E2/E3 或 K2/K3 对焦屏用于非此表格中所列照相机时，请分别参考 B、E 或 K 列。

对焦屏	EC-B/	A/L	B	C	D	E	G1	G2	G3	G4	H1	H2	H3	H4	J	K	P	M	R	T	U	F
照相机	EC-E																					
F6			⊙	⊙		⊙									⊙							
F5+DP-30	⊙	⊙	⊙			⊙									⊙							
F5+DA-30	⊙	⊙	⊙			⊙		⊙							⊙							
	(+0.5)	(+0.5)	(+0.5)					(-1)							(+0.5)							
F4+DP-20/ F4+DA-20			⊙			⊙		○	○						⊙	⊙	⊙					
						(-1)		(-1)														
F3		⊙	⊙			⊙					○	○			⊙	⊙	⊙		⊙	⊙		

- ⊙：推荐使用。
- ：在取景器中可见渐晕（照片不会受到影响）。
- △：分屏显示不会提高对焦准确度。
- ()：括号中的数据是指用于中央重点测光的曝光补偿值。当调整 F6 的曝光补偿时，请在自定义设定 b6（“对焦屏补偿”）中选择“其他对焦屏”；请注意，使用 B 或 E 以外的对焦屏时，即使曝光补偿值为 0，也必须选择“其他对焦屏”。F5 和 F4 的用户可分别使用自定义设定 18 和对焦屏曝光补偿拨盘调整曝光补偿；有关详细信息，请参阅照相机的说明书。

空白单元格：不适用于本镜头。请注意，在放大倍率为 1:1 或更高时，M 型对焦屏仍可用于显微拍摄和微距拍摄。

■ 滤镜

本镜头随附 4 种滤镜 : L37C（UV 滤镜）、A2、B2 和 O56。任何时候都必须安装有滤镜；请根据拍摄环境选择滤镜。由于具备卡口，因此更换这些镜后卡口型滤镜变得轻而易举。

■ 更换滤镜

- 逆时针旋转当前滤镜并将其取下。
- 将替换滤镜安放在镜头上，同时保持其外部边缘的点与镜头卡口安装销旁的导槽对齐，然后顺时针旋转滤镜。

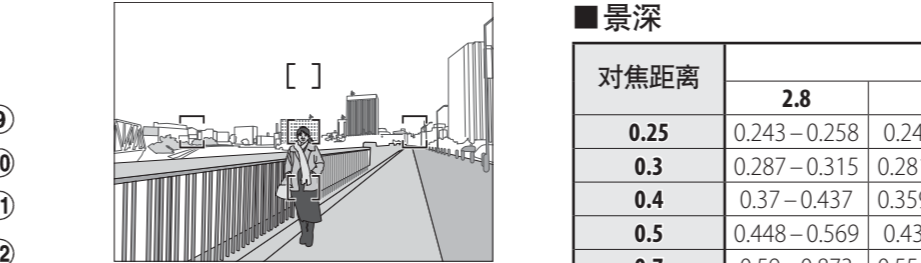

图C

与背景有一段距离的较远人物拍摄对象

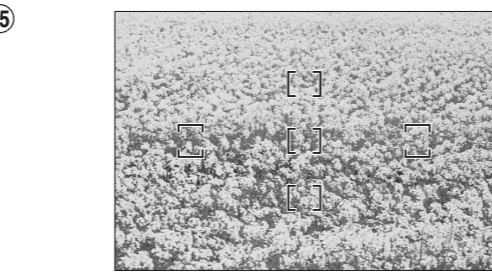

图D

一片开满鲜花的田地

■ 非 TTL 测光

使用镜后（TTL）测光时不需要曝光补偿，因为照相机将根据穿过镜头的光线量测定曝光。当使用不提供 TTL 测光的照相机时，请如下表所示调整曝光。括号中的数据指的是以 f 档为单位的曝光补偿。

胶卷	滤镜		滤光系数（曝光补偿）	
	名称	类型	日光	白炽灯灯光
黑白/彩色	L37C	紫外	1	1
仅彩色	A2	淡琥珀色	1.2 (⅓)	1.2 (⅓)
	B2	淡蓝色	1.2 (⅓)	1.2 (⅓)
仅黑白	O56	橙色	3.5 (1½)	2 (1)

■ 最小光圈锁定杆（图A）

在程序自动或快门优先自动模式下进行拍摄时将光圈锁定为 f/22。

1. 将光圈环旋转至最小光圈设定（f/22）。

2. 朝光圈环滑动锁定杆，以便锁定杆上的白点与橙点对齐。

若要解除锁定，请按相反方向滑动锁定杆。

■ 构图（图B）

与常规镜头相比，使用鱼镜头构图时需要花费更多的精力和考虑。鱼镜头不仅会由于它的宽视角而容易产生失真，还会将物体挤压进一个受限的区域：靠近中央的物体比边缘的物体显得更大且失真更少。整个场景变得更为深远，空间关系也发生变化，只需稍微改变照相机的位置即可产生全新的构图。您需特别注意避免不相干的物体（如三脚架的支脚或拍摄者的手和脚等）出现在画面中。

■ 镜头保养

- 用吹气球去除镜头表面的灰尘和浮屑。若要去除污点和指纹，可使用一块滴有少许乙醇或镜头清洁剂的干净软棉布或镜头清洁纸，以圆周运动方式从里向外进行清洁。注意不要留下污渍，也不要用手指触碰玻璃。
- 切勿使用涂料稀释剂或苯等有机溶剂清洁镜头。
- 不使用镜头时，请盖上镜头前后盖。
- 保持镜头干燥。内部构造生锈将导致无法挽回的损坏。
- 若在较长时间内不使用镜头，请将其存放在阴凉干燥的地方以防止发霉和生锈。切不可存放在直射阳光下，也不可与其石脑油或樟脑丸一起存放。
- 将镜头放置在过于炎热的地方将会使强化塑料部件受损或变形。
- 运输产品时，请在包装箱内装入足够多的缓冲材料，以减少（避免）由于冲击导致产品损坏。

■ 兼容的配件

- 半软镜头袋 CL-0715

■ 技术规格

焦距	16mm
最大光圈	f/2.8
镜头结构	5组8片
视角	180°
对焦距离指示	从0.25m至无穷远(∞)，以米和英尺为单位
距离信息	输出到照相机
光圈刻度	标准和光圈直读刻度上均为f/2.8至f/22
光圈	全自动
测光	全开光圈测光
卡口	尼康F卡口
滤镜	L37C、O56、A2和B2（镜后卡口型）
尺寸	约63mm（最大直径）×57mm（从照相机镜头卡口边缘开始的距离）；总体长度约为68mm
重量	约290g

尼康公司保留可随时更改说明书内载之硬件技术规格的权利，而无须事先通知。

景深									(m)
对焦距离	景深							复制比率	
	2.8	4	5.6	8	11	16	22		
0.25	0.243–0.258	0.24–0.262	0.236–0.267	0.23–0.276	0.224–0.288	0.215–0.312	0.206–0.35	1/10	
0.3	0.287–0.315	0.281–0.323	0.275–0.333	0.266–0.351	0.256–0.377	0.241–0.434	0.227–0.543	1/14	
0.4	0.37–0.437	0.359–0.456	0.346–0.484	0.328–0.536	0.308–0.623	0.283–0.882	0.259–1.988	1/20	
0.5	0.448–0.569	0.43–0.607	0.408–0.667	0.38–0.789	0.351–1.04	0.314–2.45	0.282–∞	1/26	
0.7	0.59–0.873	0.554–0.981	0.513–1.183	0.464–1.742	0.416–4.678	0.359–∞	0.313–∞	1/39	
1	0.772–1.46	0.705–1.83	0.635–2.85	0.555–21.01	0.482–∞	0.402–∞	0.34–∞	1/58	
∞	2.72–∞	1.93–∞	1.4–∞	1.01–∞	0.76–∞	0.55–∞	0.42–∞	1/∞	

■ 关于广角和超广角镜头的注解

下列情况下若使用广角和超广角镜头，自动对焦可能无法达到预期效果：

1 拍摄对象未填满对焦包围中的区域（图C）。

若对焦点包含前景和背景两者中的物体，照相机可能对焦于背景，从而使拍摄对象不清晰。

2 拍摄对象包含很多细节性景物（图D）。

照相机可能难以对焦于包含很多细节性景物或缺少对比度的拍摄对象。

在这些情况下，请使用手动对焦，或使用对焦锁定对焦于相同距离的其他拍摄对象后再重新构图。有关详细信息，请参阅照相机说明书中的“利用自动对焦获取良好拍摄效果”。

产品中有害物质的名称及含量							
标志	部件名称	有害物质					
		铅(Pb)	汞(Hg)	镉(Cd)	六价铬(Cr(VI))	多溴联苯(PBB)	多溴二苯醚(PBDE)
10	外壳	○	○	○	○	○	○
	机械元件	×	○	○	○	○	○
	光学元件	○	○	○	○	○	○
	电子元件	×	○	○	○	○	○

本表格依据SJ/T11364的规定编制。

○：表示该有害物质在该部件所有均质材料中的含量均在GB/T26572规定的限量要求以下。

×

×：表示该有害物质至少在该部件的某一均质材料中的含量超出GB/T26572规定的限量要求。但是，以现有的技术条件要使照相机相关产品完全不含有上述有害物质极为困难，并且上述产品都包含在《关于电气电子设备中特定含物质使用限制指令2011/65/EU》的豁免范围之内。

进口商：尼康映像仪器销售（中国）有限公司（上海市茂名南路205号瑞金大厦22楼，200020）
尼康客户支持中心服务热线：400-820-1665（周一至周日9:00–18:00，除夕下午休息）
http://www.nikon.com.cn/

在日本印刷

出版日期：2015年3月1日

中文版（简体）

保留备用

感谢您选购尼康产品。该 AF 鱼眼尼克尔 16mm f/2.8D 镜头可为照相机机身提供距离信息以进行即时 3D 矩阵测光或 3D 多传感器均衡补充闪光的闪光控制。它具有 180° 对角线视角以获取真实的鱼眼效果，但是与其他尼克尔鱼眼镜头不同，它被设计为一款能够拍摄出充满整个画面图像的镜头，其效果类似于常规镜头。除了供平常使用的 L37C UV 滤镜外，它还随附 O56、A2 和 B2 镜后卡口型滤镜（因具备卡口，滤镜可快速安装和取下）。在使用本产品前，请仔细阅读这些指南和照相机说明书，以便您在现在和今后都能充分利用您的镜头。

使用产品前请仔细阅读本使用说明书。

安全须知

请在使用前仔细阅读“安全须知”，并以正确的方法使用。本“安全须知”中记载了重要的内容，可使您能够安全、正确地使用产品，并预防对您或他人造成人身伤害或财产损失。请在阅读之后妥善保管，以便本产品的所有使用者可以随时查阅。

有关指示

本节中标注的指示和含义如下。

警告	表示若不遵守该项指示或操作不当，则有可能造成人员伤亡或负重伤的内容。
注意	表示若不遵守该项指示或操作不当，则有可能造成人员伤亡、以及有可能造成物品损害的内容。

本节使用以下图示和符号对必须遵守的内容作分类和说明。

图示和符号的实例

△	△符号表示唤起注意（包括警告）的内容。在图示中或图示附近标有具体的注意内容（左图之例为当心触电）。
⊙	⊙符号表示禁止（不允许进行的）的行为。在图示中或图示附近标有具体的禁止内容（左图之例为禁止拆解）。
⦿	⦿符号表示强制执行（必需进行）的行为。在图示中或图示附近标有具体的强制执行内容（左图之例为取出电池）。

警告	
禁止拆解	切勿自行拆解、修理或改装。否则将会造成触电、发生故障并导致受伤。
禁止触碰	当产品由于跌落而破损使得内部外露时，切勿用手触碰外露部分。否则将会造成触电、或由于破损部分而导致受伤。取出照相机电池，并委托经销商或尼康授权的维修服务中心进行修理。
立即委托修理	当发现产品过热、冒烟或发出焦味等异常时，请立刻取出照相机电池。若在此情况下继续使用，将会导致火灾或灼伤。取出电池时，请小心勿被烫伤。取出电池，并委托经销商或尼康授权的维修服务中心进行修理。
取出电池	
立即委托修理	切勿浸入水中或接触到水，或被雨水淋湿。否则将会导致起火或触电。
禁止接触水	
禁止使用	切勿在有可能会起火、爆炸的场所使用。在有丙烷气、汽油、可燃性喷雾剂等易燃性气体、粉尘的场所使用产品，将会导致爆炸或火灾。
禁止观看	切勿用镜头或照相机直接观看太阳或强光。否则将会导致失明或视觉损伤。

注意	
当心触电	切勿用湿手触碰。否则将有可能导致触电。
禁止放置	切勿在婴幼儿伸手可及之处保管产品。否则将有可能导致受伤。
小心使用	进行逆光拍摄时，务必使太阳充分偏离视角。阳光会在照相机内部聚焦，并有可能导致火灾。太阳偏离视角的距离微小时，也有可能导致火灾。
妥善保存	不使用时请盖上镜头盖，或保存在没有阳光照射处。阳光会聚焦，并有可能导致火灾。
小心移动	进行移动时，切勿将照相机或镜头安装在三脚架上。摔倒、碰撞时将有可能导致受伤。
禁止放置	切勿放置于封闭的车辆中、直射阳光下或其它异常高温之处。否则将对内部零件造成不良影响，并导致火灾。

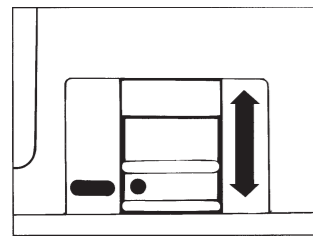
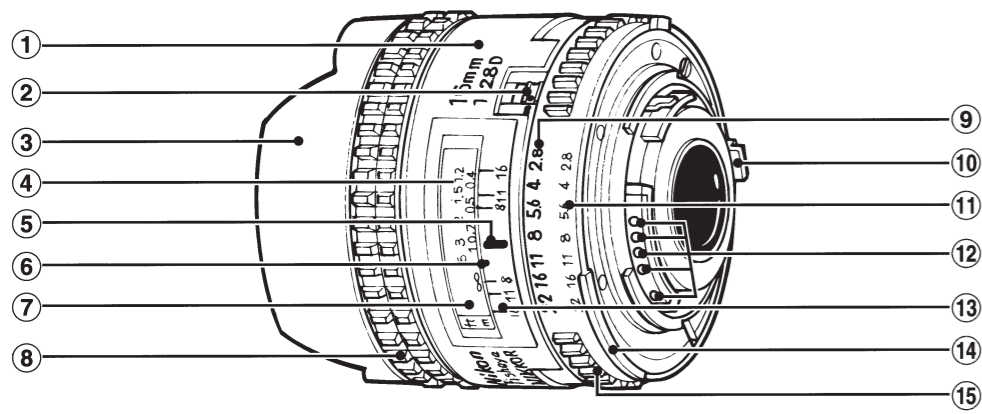

Figure A

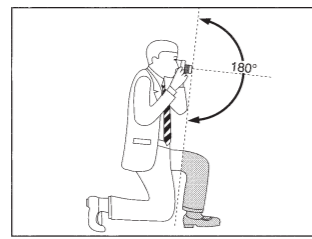

Figure B

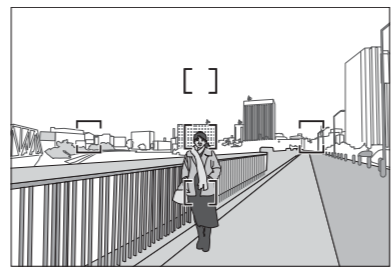

Figure C
A far-off portrait subject at some distance from the background

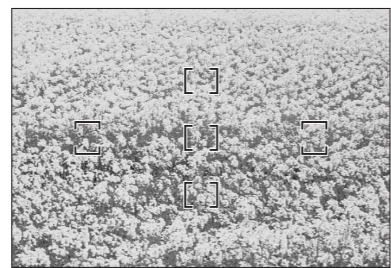

Figure D
A field of flowers

■ Depth of Field (Metric)

Focus distance	Depth of field							Reproduction ratio
	2.8	4	5.6	8	11	16	22	
0.25	0.243–0.258	0.24–0.262	0.236–0.267	0.23–0.276	0.224–0.288	0.215–0.312	0.206–0.35	1/10
0.3	0.287–0.315	0.281–0.323	0.275–0.333	0.266–0.351	0.256–0.377	0.241–0.434	0.227–0.543	1/14
0.4	0.37–0.437	0.359–0.456	0.346–0.484	0.328–0.536	0.308–0.623	0.283–0.882	0.259–1.988	1/20
0.5	0.448–0.569	0.43–0.607	0.408–0.667	0.38–0.789	0.351–1.04	0.314–2.45	0.282–∞	1/26
0.7	0.59–0.873	0.554–0.981	0.513–1.183	0.464–1.742	0.416–4.678	0.359–∞	0.313–∞	1/39
1	0.772–1.46	0.705–1.83	0.635–2.85	0.555–21.01	0.482–∞	0.402–∞	0.34–∞	1/58
∞	2.72–∞	1.93–∞	1.4–∞	1.01–∞	0.76–∞	0.55–∞	0.42–∞	1/∞

■ Depth of Field (Imperial)

Focus distance	Depth of field							Reproduction ratio
	2.8	4	5.6	8	11	16	22	
0.85	9 13/16 in. – 10 1/8 in.	9 11/16 in. – 10 1/2 in.	9 5/8 in. – 11 1/8 in.	9 3/8 in. – 11 1/4 in.	8 1/2 in. – 1 ft 3 1/8 in.	8 3/8 in. – 1 ft 1 1/8 in.	8 1/4 in. – 1 ft 3 13/16 in.	1/11
1	11 1/4 in. – 1 ft 1 1/8 in.	11 3/8 in. – 1 ft 1 1/2 in.	10 15/16 in. – 1 ft 1 1/4 in.	10 3/4 in. – 1 ft 2 1/8 in.	10 3/8 in. – 1 ft 3 3/8 in.	9 5/8 in. – 1 ft 3 1/2 in.	8 15/16 in. – 1 ft 10 9/16 in.	1/14
1.3	1 ft 1 13/16 in. – 1 ft 4 1/4 in.	1 ft 1 7/8 in. – 1 ft 4 1/4 in.	1 ft 1 1/2 in. – 1 ft 5 13/16 in.	1 ft 7/8 in. – 1 ft 7 7/8 in.	11 1/4 in. – 1 ft 10 1/8 in.	10 13/16 in. – 2 ft 6 in.	9 5/8 in. – 4 ft 7 7/8 in.	1/19
1.5	1 ft 8 3/8 in. – 1 ft 8 7/8 in.	1 ft 3 1/2 in. – 1 ft 9 3/8 in.	1 ft 3 in. – 1 ft 10 15/16 in.	1 ft 2 1/2 in. – 2 ft 2 3/8 in.	1 ft 1 3/8 in. – 2 ft 8 13/16 in.	11 1/4 in. – 4 ft 9 1/8 in.	10 15/16 in. – ∞	1/24
2	1 ft 8 1/2 in. – 2 ft 4 1/8 in.	1 ft 7 1/2 in. – 2 ft 7 7/8 in.	1 ft 6 1/2 in. – 3 ft 3/8 in.	1 ft 4 1/4 in. – 3 ft 11 1/8 in.	1 ft 3 3/8 in. – 6 ft 7 7/8 in.	1 ft 1 1/4 in. – ∞	11 13/16 in. – ∞	1/33
3	2 ft 4 3/8 in. – 4 ft 2 1/8 in.	2 ft 2 3/8 in. – 5 ft 10 1/8 in.	1 ft 11 1/8 in. – 7 ft 1 1/8 in.	1 ft 8 13/16 in. – 20 ft 1 7/8 in.	1 ft 6 3/8 in. – ∞	1 ft 3 3/8 in. – ∞	1 ft 1 3/8 in. – ∞	1/53
5	3 ft 4 3/8 in. – 10 ft 4 in.	2 ft 11 1/8 in. – 20 ft 1 in.	2 ft 6 1/8 in. – ∞	2 ft 1 13/16 in. – ∞	1 ft 9 1/8 in. – ∞	1 ft 5 3/8 in. – ∞	1 ft 2 3/8 in. – ∞	1/92
∞	8 ft 11 in. – ∞	6 ft 3 3/8 in. – ∞	4 ft 7 1/8 in. – ∞	3 ft 3 1/8 in. – ∞	2 ft 5 3/8 in. – ∞	1 ft 9 1/8 in. – ∞	1 ft 4 10/16 in. – ∞	1/∞

English

Thank you for purchasing a Nikon product. The AF Fisheye-Nikkor 16mm f/2.8D lens supplies distance information to the camera body for instantaneous 3D matrix metering or 3D multi-sensor balanced fill-flash flash control. It has a 180° diagonal angle of view for a true fisheye effect, but, unlike other Nikkor fisheye lenses, it is designed to produce images that fill the entire frame, just like those produced by conventional lenses. In addition to an L37C UV filter for normal use, it comes with O56, A2, and B2 rear-mounted filters that can be quickly swapped in and out thanks to their bayonet mounts. Before using this product, please carefully read both these instructions and the camera manual so you get the maximum value from your lens now and for years to come.

■ For Your Safety

▲ CAUTIONS

- **Do not disassemble.** Touching the internal parts of the camera or lens could result in injury. In the event of malfunction, the product should be repaired only by a qualified technician. Should the product break open as the result of a fall or other accident, remove the camera battery and/or disconnect the AC adapter and then take the product to a Nikon-authorized service center for inspection.
- **Turn the camera off immediately in the event of malfunction.** Should you notice smoke or an unusual smell coming from the equipment, immediately unplug the AC adapter and remove the camera battery, taking care to avoid burns. Continued operation could result in fire or injury. After removing or disconnecting the power source, take the equipment to a Nikon-authorized service center for inspection.
- **Do not use in the presence of flammable gas.** Operating electronic equipment in the presence of flammable gas could result in explosion or fire.
- **Do not look at the sun through the lens or the camera viewfinder.** Viewing the sun or other bright light source through the lens or viewfinder could cause permanent visual impairment.
- **Keep out of reach of children.** Particular care should be taken to prevent infants from putting the batteries or other small parts into their mouths.
- **Observe the following precautions when handling the lens and camera:**
 - Keep the lens and camera dry. Failure to observe this precaution could result in fire or electric shock.
 - Do not handle the lens or camera with wet hands. Failure to observe this precaution could result in electric shock.
 - Keep the sun well out of the frame when shooting backlit subjects. Sunlight focused into the camera when the sun is in or close to the frame could cause a fire.
 - If the lens will not be used for an extended period, attach the front and rear lens caps and store the lens out of direct sunlight. If left in direct sunlight, the lens could focus the sun's rays onto flammable objects, causing fire.

■ Parts of the Lens

- | | |
|--|---------------------------------|
| ① Lens barrel | ⑨ Aperture scale |
| ② Minimum aperture lock lever | ⑩ Aperture indexing post |
| ③ Lens hood | ⑪ Aperture-direct-readout scale |
| ④ Focus distance indicator | ⑫ CPU contacts |
| ⑤ Focal length/aperture/mounting index | ⑬ Depth-of-field indicators |
| ⑥ Infrared compensation index (white) | ⑭ Meter coupling ridge |
| ⑦ Focus distance indicator window | ⑮ Aperture ring |
| ⑧ Focus ring | |

■ Notices

- Keep the CPU lens contacts clean and be careful not damage the CPU contacts.
- Do not attach the following accessories directly to the lens: PK-1 or PK-11 auto extension rings, K1 rings, or BR-4 auto rings (the PK-11A and BR-8 can be used in place of the PK-11 and BR-4, respectively). Failure to observe this precaution will result in damage to the CPU contacts or other parts of the lens. Other lens accessories may not be compatible with the camera; be sure to consult the camera manual before use.
- The lens can not be used with the DX-1 viewfinder for Nikon F3AF cameras.

■ Focus

Autofocus is available with Nikon autofocus cameras; to focus manually, rotate the focus ring until the image in the viewfinder is clearly defined.

■ Focusing Screens

The cameras listed in the "Focusing Screens" table support a variety of focusing screens for use with different lenses or in different situations. The screens listed in the table are suited for use with this lens.

When using B2/B3, E2/E3, or K2/K3 screens with cameras not listed in this table, refer respectively to columns B, E, or K.

Camera	Screen	EC-B/	EC-E	A/L	B	C	D	E	G1	G2	G3	G4	H1
F6			⊗	⊗	⊗			⊗					
F5+DP-30		⊗	⊗	⊗	⊗			⊗		⊗			
F5+DA-30		⊗ (+0.5)	⊗ (+0.5)	⊗ (+0.5)	⊗			⊗		⊗ (-1)			
F4+DP-20/F4+DA-20					⊗			⊗	○	○			
F3			⊗	⊗				⊗					○

Camera	Screen	H2	H3	H4	J	K	P	M	R	T	U	F
F6					⊗							
F5+DP-30					⊗							
F5+DA-30					⊗ (+0.5)							
F4+DP-20/F4+DA-20					⊗	⊗	⊗					
F3	○				⊗	⊗	⊗		⊗	⊗		

- ⊗: Recommended.
- : Vignetting visible in viewfinder (photographs are not affected).
- △: Split-screen display does not improve focus accuracy.
- (): Figures in parentheses give the exposure compensation for center-weighted metering. Select "Other screen" for Custom Setting b6 ("Screen comp.") when adjusting exposure compensation for the F6; note that with screens other than B or E, "Other screen" must be selected even when the value for exposure compensation is 0. Users of the F5 and F4 can adjust exposure compensation using Custom Setting 18 or the focusing screen exposure compensation dial, respectively; see the camera manual for details.

Empty cell: Not suited to use with this lens. Note that type M screens can however be used for photomicrography and macro photography at magnifications of 1 : 1 or higher.

■ Filters

The lens is supplied with four filters: the L37C (a UV filter), A2, B2, and O56. A filter must be attached at all times; choose a filter according to shooting conditions. Thanks to their bayonet mounts, exchanging these rear-mounted filters is a snap.

■ Exchanging Filters

- 1 Rotate the current filter counterclockwise and remove it.
- 2 Place the replacement filter on the lens, keeping the dot on its outside rim aligned with the groove next to the mounting pin on the lens bayonet mount, and then rotate the filter clockwise.

■ Non-TTL Metering

No exposure compensation is required with through-the-lens (TTL) metering, as the camera meters exposure based on the amount of light passing through the lens. When using cameras that do not offer TTL metering, adjust exposure as shown in the table below. Figures in parentheses indicate the exposure compensation in f/stops.

Film	Filter		Filter factor (exposure compensation)	
	Name	Type	Sunlight	Incandescent lighting
Black-and-white/color	L37C	Ultraviolet	1	1
	A2	Light amber	1.2 (1/2)	1.2 (1/2)
Color only	B2	Light blue	1.2 (1/2)	1.2 (1/2)
	O56	Orange	3.5 (1%)	2 (1)

■ The Minimum Aperture Lock Lever (Figure A)

Lock aperture at f/22 when shooting in programmed auto or shutter-priority auto mode.

1. Rotate the aperture ring to the minimum aperture setting (f/22).
2. Slide the lock lever toward the aperture ring so that the white dot on the lock lever aligns with the orange dot.

To release the lock, slide the lever in the opposite direction.

■ Composition (Figure B)

Framing shots with a fisheye lens requires even more planning and thought than would be needed with a conventional lens. Not only are fisheye lenses prone to distortion due to their wide angle of view, but they also squeeze objects to fit in a limited area: objects near center are larger and less distorted than those at the edges. The entire field is pushed into the distance and spatial relations are transformed, with whole new compositions revealed by the slightest change in camera position. Care is required to prevent extraneous objects, such as the legs of a tripod or the photographer's hands and feet, appearing in the frame.

■ Lens Care

- Use a blower to remove dust and lint from the lens surfaces. To remove smudges and fingerprints, apply a small amount of ethanol or lens cleaner to a soft, clean cotton cloth or lens-cleaning tissue and clean from the center outwards using a circular motion, taking care not to leave smears or touch the glass with your fingers.
- Never use organic solvents such as paint thinner or benzene to clean the lens.
- Attach the front and rear caps when the lens is not in use.
- Keep the lens dry. Rusting of the internal mechanism can cause irreparable damage.
- If the lens will not be used for an extended period, store it in a cool, dry location to prevent mold and rust. Do not store in direct sunlight or with naphtha or camphor moth balls.
- Leaving the lens in extremely hot locations could damage or warp parts made from reinforced plastic.

■ Compatible Accessories

- Flexible Lens Pouch CL-0715

■ Specifications

Focal length	16 mm
Maximum aperture	f/2.8
Lens construction	8 elements in 5 groups
Angle of view	180°
Focus distance indicator	Graduated in meters and feet from 0.25 m (1 ft) to infinity (∞)
Distance information	Output into camera
Aperture scale	f/2.8 to f/22 on both standard and aperture-direct readout scales
Diaphragm	Fully automatic
Metering	Full aperture
Mount	Nikon F mount
Filters	L37C, O56, A2 and B2 (rear-mount bayonet-type)
Dimensions	Approx. 63 mm (maximum diameter) × 57 mm (distance from camera lens mount flange); overall length is approx. 68 mm
Weight	Approx. 290 g (10.2 oz)

Nikon reserves the right to change the specifications of the hardware described in this manual at any time and without prior notice.

■ A Note on Wide- and Super Wide-Angle Lenses

Autofocus may not provide the desired results with wide- and super wide-angle lenses in the following situations:

- 1 **The subject does not fill the area enclosed by the focus brackets (Figure C).**
If the focus point contains both foreground and background objects, the camera may focus on the background and the subject may be out of focus.
- 2 **The subject contains many fine details (Figure D).**
The camera may have difficulty focusing on subjects that contain many fine details or that are lacking in contrast.

In these cases, use manual focus, or use focus lock to focus on another subject at the same distance and then recompose the photograph. For more information, see "Getting Good Results with Autofocus" in the camera manual.